

Additional Installation, Operation and
Maintenance Instructions



e-SV Series

Multistage Vertical Pump / Pump Unit

Table of Contents

1	Introduction and Safety	5
1.1	Introduction	5
1.2	Safety	5
1.2.1	Danger levels and safety symbols	5
1.2.2	User safety	6
1.2.3	Protection of the environment.....	7
1.2.4	Sites exposed to ionizing radiations.....	7
2	Handling and Storage.....	8
2.1	Handling of the packed unit	8
2.2	Unit inspection upon delivery.....	9
2.3	Unit handling	9
2.4	Storage	11
3	Technical Description	12
3.1	Designation	12
3.2	Data plate	12
3.3	Identification code	13
3.4	Names of the main components	15
3.5	Intended use.....	16
3.6	Improper use	16
3.7	Use in water distribution networks for human consumption	17
3.8	Special applications	17
4	Installation	18
4.1	Precautions	18
4.2	Assembly of the motor.....	19
4.3	Mechanical installation.....	21
4.3.1	Installation area	21
4.3.2	Permitted positions	21
4.3.3	Installation on concrete foundation.....	21
4.3.4	Fastening of the unit	21
4.3.5	Reducing vibrations	22
4.4	Hydraulic connection	22
4.4.1	Guidelines for the hydraulic system	23
4.4.2	Forces and torques applicable to the flanges	24
4.5	Electrical connection	25
4.5.1	Ground.....	25
4.5.2	Guidelines for electrical connection.....	26
4.5.3	Guidelines for the electrical control panel.....	26
4.5.4	Guidelines for the motor.....	26

4.5.5	Operation with frequency converter	28
5	Use and operation	29
5.1	Precautions	29
5.2	Filling - Priming	30
5.2.1	Positive suction head installation	30
5.2.2	Suction lift installation	30
5.3	Rotation sense check (three-phase motors).....	31
5.3.1	Wrong rotation direction	32
5.4	Start-up	32
5.5	Stopping	33
6	Maintenance	34
6.1	Precautions	34
6.2	Maintenance every 4000 hours of operation, or every year	34
6.3	Long periods of inactivity.....	34
6.4	Tightening torques of the threaded connections.....	35
6.5	Spare parts ordering	35
7	Troubleshooting.....	36
7.1	Precautions	36
7.2	The unit does not start	36
7.3	The differential protection device (RCD) is activated	36
7.4	The thermal overload protection triggers or the fuses trip	36
7.5	The thermal overload protection triggers.....	37
7.6	The motor becomes excessively hot	37
7.7	The unit runs but there is little or no flow rate	37
7.8	When switched off, the unit turns in the opposite direction	37
7.9	The unit produces excessive noise and/or vibrations	38
7.10	The unit starts up too frequently (automatic start/stop).....	38
7.11	The unit never stops (automatic start/stop)	38
7.12	The unit is leaking	39
7.13	The frequency converter is in error mode or turned off.....	39
8	Technical Information	40
8.1	Operating environment	40
8.2	Temperature of pumped liquid	40
8.3	Maximum head.....	40
8.4	Maximum operating pressure	45
8.5	Maximum number of starts per hour.....	46
8.6	Protection class.....	46
8.7	Electrical specifications	46
8.8	Sound pressure	46
8.9	Materials in contact with the liquid	47
8.10	Mechanical seal	47
9	Disposal.....	48

9.1	Precautions	48
9.2	WEEE 2012/19/EU (50 Hz)	48
10	Declarations.....	49
10.1	Pump unit	49
10.2	Pump.....	50
11	Warranty	51
11.1	Information	51

1 Introduction and Safety

1.1 Introduction

Purpose of this manual

This manual provides information on how to do the following in the correct manner:

- Installation
- Operation
- Maintenance.



CAUTION:

This manual is an integral part of the unit. Make sure to have read and understood the manual before installing the unit and putting it to use. The manual must always be made available to the user, stored in the proximity of the unit, and well kept.

Supplementary instructions

The instructions and warnings of this manual apply to the standard unit as described in the sale documentation. Special version pumps may be supplied with supplementary instruction manuals. For situations not considered in the manual or in the sales document, contact Xylem or the Authorised Distributor.



1.2 Safety

1.2.1 Danger levels and safety symbols







Before using the unit, the user must read, understand and comply with the indications of the danger warnings in order to avoid the following risks:

- Injuries and health hazards
- Damage to the product
- Unit malfunction.

Danger levels

Hazard level	Indication
 DANGER:	It identifies a dangerous situation which, if not avoided, causes serious injury, or even death.
 WARNING:	It identifies a dangerous situation which, if not avoided, may cause serious injury, or even death.
 CAUTION:	It identifies a dangerous situation which, if not avoided, may cause small or medium level injuries.
NOTICE:	It identifies a situation which, if not avoided, may cause damage to property but not to people.

Complementary symbols

Symbol	Description
	Electrical hazard
	Hot surface hazard
	Danger, system pressurized
	Do not use flammable liquids
	Do not use corrosive liquids
	Read the instruction manual

1.2.2 User safety

Strictly comply with current health and safety regulations.



WARNING:

This unit must be used only by qualified users. Qualified users are people able to recognise the risks and avoid hazards during installation, use and maintenance of the unit.

Inexperienced users



WARNING:

- For EU countries: this product may be used by children aged 8 years and above and persons with reduced physical, sensory or mental capabilities, or who lack experience and knowledge, provided that they are being supervised and have been instructed on how to use it safely, and understand the hazards involved. Children must not play with the product. Cleaning and maintenance must not be carried out by children without supervision.
- For countries outside the EU: this product is not intended for use by persons (including children) with reduced physical, sensory or mental capabilities, or who lack experience and knowledge, unless they are being supervised and have been instructed on how to use it by a person responsible for their safety. Children should be supervised to ensure that they do not play with the product.

1.2.3 Protection of the environment

Disposal of packaging and product

Comply with the current regulations on sorted waste disposal.

Leaking of fluid

If the unit contains lubricating fluid, take appropriate measures to prevent the dispersion of leaks into the environment.

1.2.4 Sites exposed to ionizing radiations



WARNING: Ionizing radiation hazard

If the unit has been exposed to ionizing radiations, implement the necessary safety measures for the protection of people. If the unit needs to be despatched, inform the carrier and the recipient accordingly, so that appropriate safety measures can be put in place.

2 Handling and Storage

2.1 Handling of the packed unit



WARNING: Crushing hazard (limbs)
The unit and its components may be heavy: risk of crushing.



WARNING:
Always wear personal protective equipment.



WARNING:
Check the gross weight marked on the packaging.



WARNING:
Handle the unit in compliance with the current regulations on "manual load handling", to avoid undesirable ergonomic conditions causing risks of back-spine injury.



WARNING:
Take appropriate measures during transport, installation and storage to prevent contamination from external substances.

Depending on the model, the Manufacturer delivers the unit and its components in:

1. A cardboard box, or
2. A cardboard box with wooden base.

The type 2 packaging is intended for transport with a forklift truck; the lifting points are indicated in the figure.

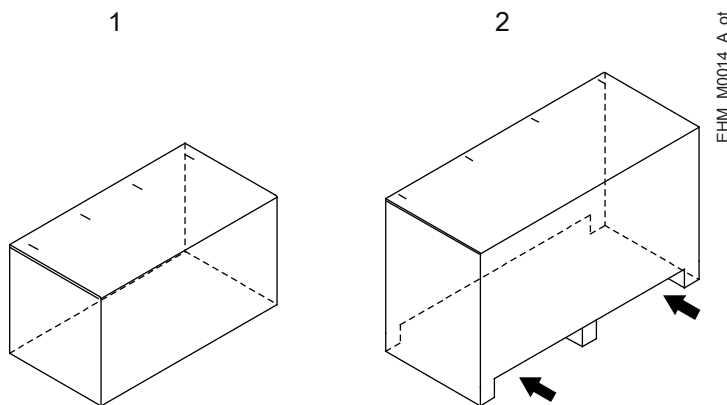

2.2 Unit inspection upon delivery

Inspect the package

1. Check that quantity, descriptions and product codes match the order.
2. Check the packaging for any damage or missing components.
3. In case of immediately detectable damage or missing parts:
 - accept the goods with reserve, indicating any findings on the transport document, or
 - reject the goods, indicating the reason on the transport document.

In both cases, promptly contact Xylem or the Authorised Distributor from whom the product was purchased.

Unpacking and inspection of the unit



CAUTION: Cut and abrasion hazard

Always wear personal protective equipment.

1. Remove packing materials from the product.
2. Release the unit by removing the screws and/or cutting the straps, if fitted.
3. Check the unit for integrity and to make sure that there are no missing components.
4. In case of damage or missing components, promptly contact Xylem or the Authorised Distributor.

2.3 Unit handling



WARNING:

Use cranes, ropes, lifting straps, hooks and clasps that comply with current regulations and that are suitable for the specific use.

NOTICE:

Make sure that the harnessing does not hit and/or damage the unit.



WARNING:

Lift and handle the unit slowly to avoid stability issues.



WARNING:

During handling, make sure to avoid injury to people and animals, and/or damage to property.



WARNING:

Do not use eyebolts screwed on the motor for lifting the unit.

NOTICE:

The pump is shipped by the Manufacturer with two shims to block the shaft and the impeller stack; always handle the pump with the shims installed to prevent damage. **Also see Assembly of the motor on page 19.**

The unit must be harnessed and lifted as shown in the figures.

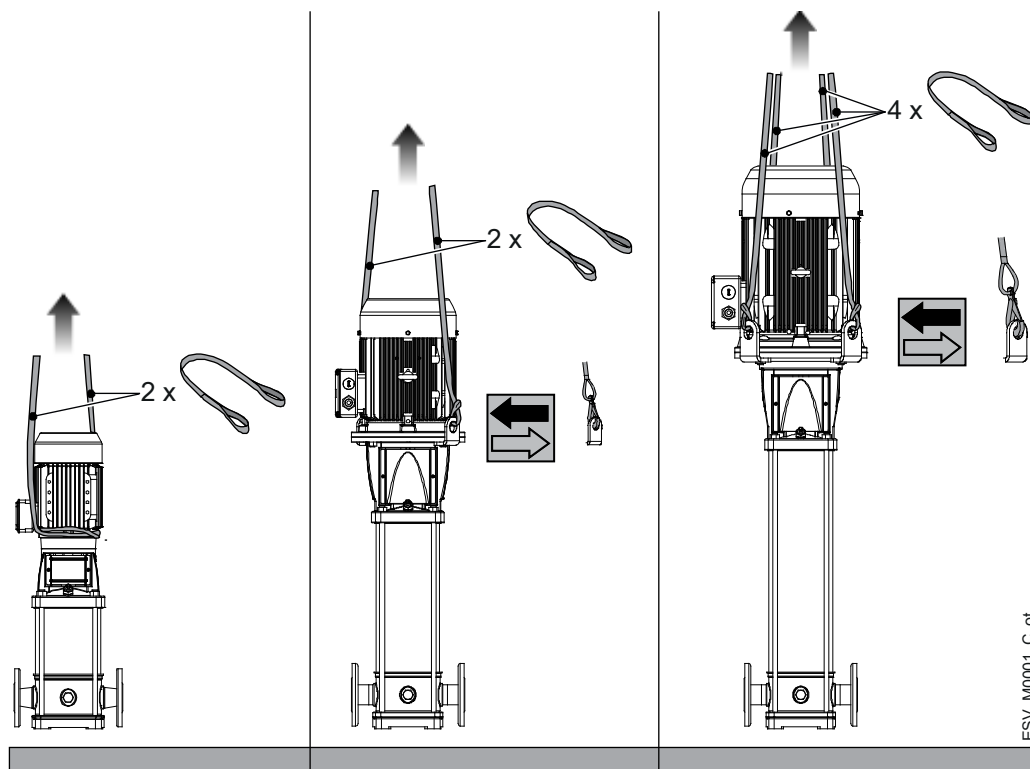

The eyebolts must only be used to move the unit upright from its horizontal position on the ground, and only for as long as strictly necessary. See the figures below.

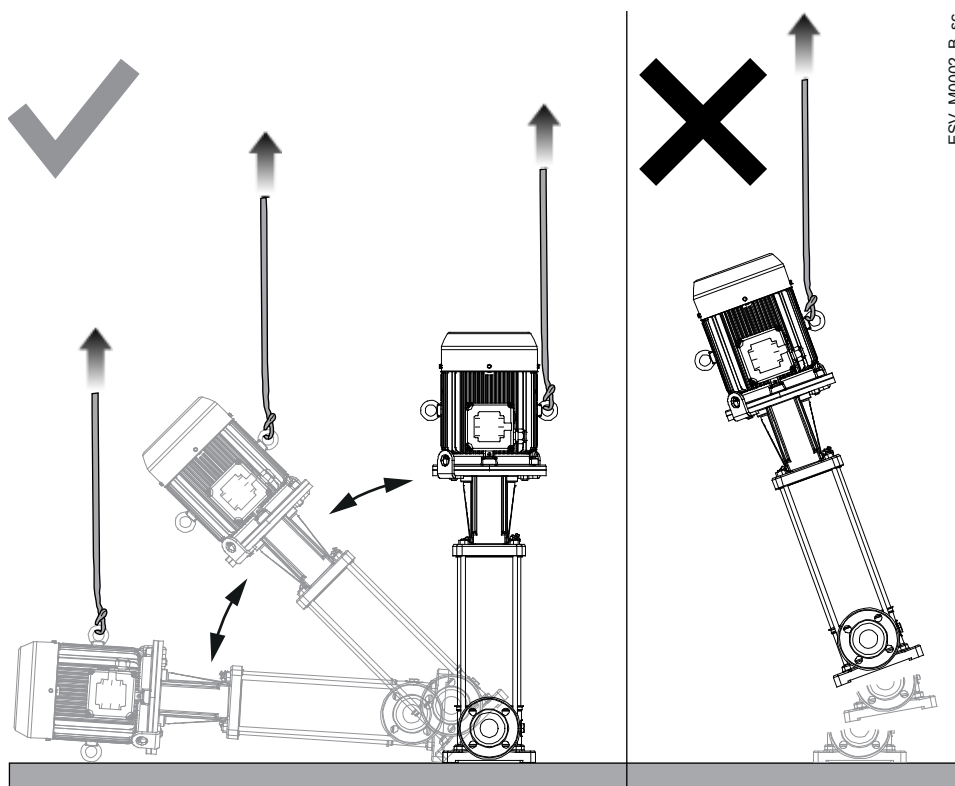

2.4 Storage

Storage of the packed unit

The unit must be stored:

- In a covered and dry place
- Away from heat sources
- Protected from dirt
- Protected from vibrations
- At an ambient temperature between -5°C and +40°C (23°F and 140°F), and relative humidity between 5% and 95%.

NOTICE:

Do not place heavy loads on top of the unit.

NOTICE:

Protect the unit from collisions.

Long-term storage of the unit

1. Empty the unit by unscrewing the drain plug; this operation is essential in environments with cold temperatures. Otherwise, any residual liquid in the unit could have an adverse effect on its condition and performance.



2. Follow the same instructions for the storage of the packed unit.

For more information on long-term storage contact the Xylem sales company or Authorised Distributor.

3 Technical Description

3.1 Designation

Multistage vertical centrifugal pump unit, non-self-priming.

The product may be supplied as a pump unit (pump and motor), or as pump only.

3.2 Data plate

1, 3, 5, 10, 15, 22SV

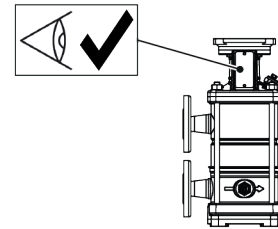
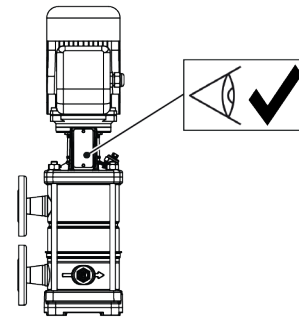
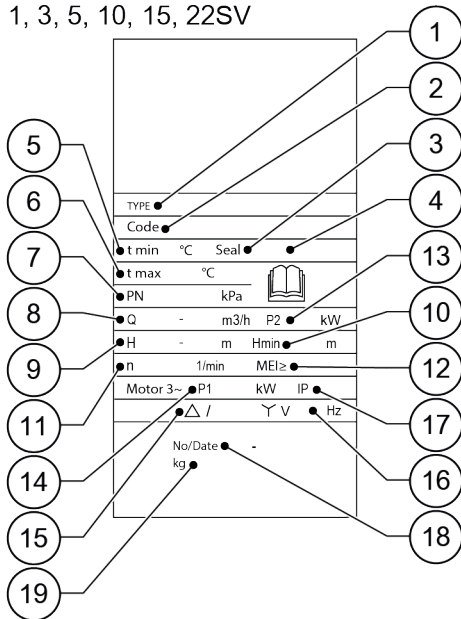

ESV_M0004_B_sc

33, 46, 66, 92, 125SV

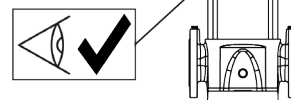
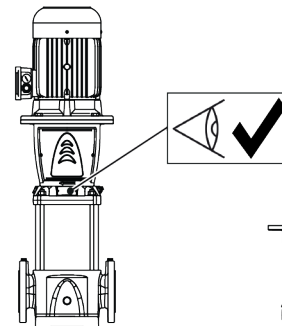
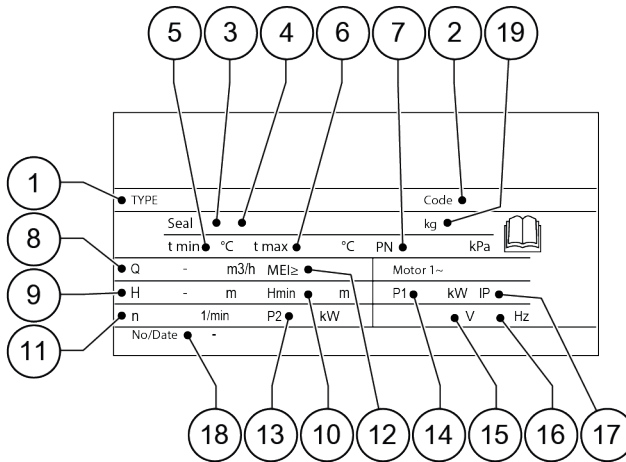

Position number	Description	Position number	Description
1	Pump or pump unit type	11	Speed
2	Product code	12	Minimum efficiency index
3	Mechanical seal materials identification code	13	Pump rated power
4	O-ring material identification code	14	Pump unit power consumption (*)
5	Minimum liquid operating temperature	15	Rated voltage range (*)
6	Maximum liquid operating temperature	16	Frequency (*)

7	Maximum operating pressure	17	Protection class (*)
8	Flow rate range	18	Serial number + manufacturing date
9	Head range	19	Weight
10	Minimum head	-	-

(*) Data present only on the pump unit plate

Additional liquid temperature plate

It is applied on the units where the maximum working temperature of the liquid exceeds the limit of 90°C (194°F), foreseen by the standard EN 60335-2-41, with Un (V) ≤ 480 V (3~) or ≤ 250 V (1~).

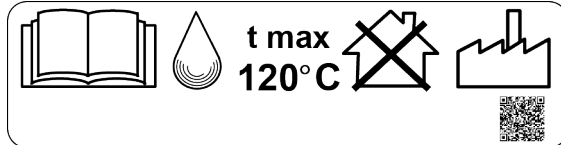

ESV_M0025_A_sc

3.3 Identification code

Modes 1, 3, 5, 10, 15, 22SV

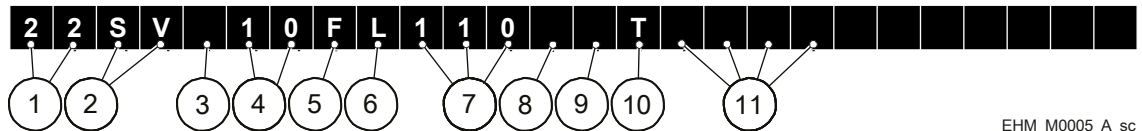

EHM_M0005_A_sc

Position number	Description	Notes
1	Rated flow rate	22 = m3/h
2	Series name	SV
3	Motor operation	Empty = standard H = with Hydrovar® X = other drivers E = e-SM
4	Number of impeller	10 = 10 impellers
5	Standard materials	F = AISI 304, round flanges (PN 25) T = AISI 304, oval flanges (PN 16) R = AISI 304, overlapping ports, round flanges (PN 25) N = AISI 316, round flanges (PN 25) V = AISI 316, Victaulic® couplings (PN 25) P = AISI 316, Victaulic® couplings (PN 40) C = AISI 316, DIN 32676 Clamp couplings (PN 25) K = AISI 316, DIN 11851 thread couplings (PN 25) X = custom version
6	Special versions	Empty = standard L = Low NPSH, round flanges, PN 25 (versions F, N, R) H = high temperature 150°C, round flanges, PN 25 (versions F, N) B = high temperature 180°C, round flanges, PN 25 (version N) E = passivated and electropolished (versions N, V, C, K, P) W = high temperature 150° and low NPSH (versions F, N) Y = high temperature 180° and low NPSH (version N) U = passivated, electropolished and low NPSH (versions N, V, C, K, P) I = high temperature 150°, passivated and electropolished (version N) S = high temperature 180°, passivated and electropolished

		(version N) A = high temperature 150°, passivated, electropolished and low NPSH (version N) D = high temperature 180°, passivated, electropolished and low NPSH (version N) X = custom version
7	Motor rated power	kW X 10
8	Number of poles	Empty = 2 poles 4 = 4 poles P = e-SM
9	Frequency	Empty = 50 Hz 6 = 60 Hz 0 = e-SM
10	Phase	Empty = pump only M = single-phase T = three-phase
11	Other information	Empty = standard version Other = see technical catalogue

Models 33, 46, 66, 92, 125SV

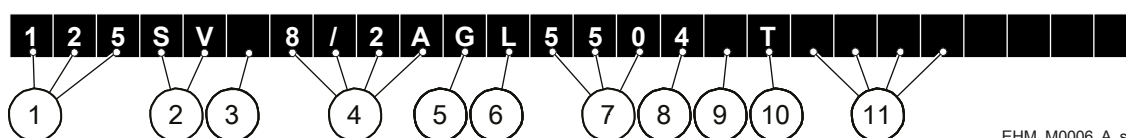

EHM_M0006_A_sc

Position number	Description	Notes
1	Rated flow rate	125 = m3/h
2	Series name	SV
3	Motor operation	Empty = standard H = with Hydrovar® X = other drivers
4	Number of impeller	8/2A = 8 impellers, 2 of which with a smaller external diameter, type A or B
5	Standard materials	G = AISI 304/Cast iron, round flanges (PN16/25/40 depending on model) N = AISI 316, round flanges (PN16/25/40 depending on model) P = AISI 316, round flanges (PN 40) X = custom version
6	Special versions	Empty = standard L = Low NPSH, round flanges, PN 25 (versions G, N) H = high temperature 150°C, round flanges, PN 25 (versions G, N) B = high temperature 180°C, round flanges, PN 25 (version N) E = passivated and electropolished (version N) W = high temperature 150° and low NPSH (versions G, N) Y = high temperature 180° and low NPSH (version N) U = passivated, electropolished and low NPSH (version N) I = high temperature 150°, passivated and electropolished (version N) S = high temperature 180°, passivated and electropolished (version N) A = high temperature 150°, passivated, electropolished and low NPSH (version N) D = high temperature 180°, passivated, electropolished and low NPSH (version N) X = custom version

7	Motor rated power	kW X 10
8	Number of poles	Empty = 2 poles 4 = 4 poles
9	Frequency	Empty = 50 Hz 6 = 60 Hz
10	Phase	Empty = pump only M = single-phase T = three-phase
11	Other information	Empty = standard version Other = see technical catalogue

Marks of safety approval

For products with a mark of electrical-related safety approval such as IMQ, TUV, IRAM, etc., the approval refers exclusively to the pump unit.

3.4 Names of the main components

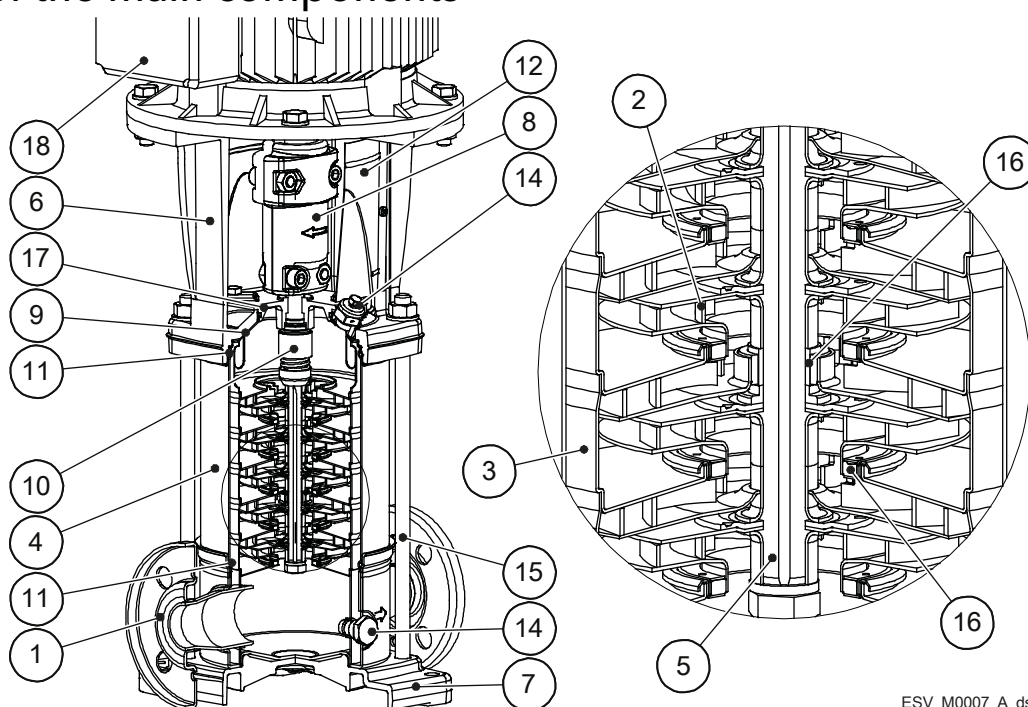

ESV_M0007_A_ds

Position number	Description	Position number	Description
1	Pump body	10	Mechanical seal
2	Impeller	11	Elastomers
3	Diffuser	12	Coupling protection
4	Outer sleeve	13	Shaft sleeve and bush
5	Shaft	14	Fill and drain plug
6	Motor adapter	15	Tie rod
7	Base plinth	16	Wear ring
8	Coupling	17	Seal housing
9	Disk	18	Motor

3.5 Intended use

- Pressure boosting and water supply systems
- Washing and cleaning sector, including washing of vehicles
- Circulation of hot and cold liquids, for example water or water & glycol, for heating, cooling and air conditioning systems
- Water treatment applications
- Transfer of moderately aggressive liquids
- Irrigation
- Firefighting systems.

Observe the operating limits in Technical Information on page 40.

Pumped liquids

- Clean
- Chemically and mechanically non aggressive
- Hot water
- Cold water.

3.6 Improper use



WARNING:

The unit was designed and built for the use described in section Intended use. Any other uses are prohibited, as they could compromise the safety of the user and the efficiency of the unit itself.



DANGER:

It is prohibited to use this unit to pump flammable and/or explosive liquids.



DANGER: Potentially explosive atmosphere hazard

It is prohibited to start the unit in environments with potentially explosive atmospheres or with combustible dusts.

Examples of improper use

- Pumping liquids not compatible with the construction materials of the unit
- Pumping hazardous, toxic, explosive, flammable or corrosive liquids
- Pumping drinking liquids other than water, for example wine or milk
- Pumping liquids containing abrasive, solid, or fibrous substances
- Using the unit for flow rates exceeding the flow rate indicated in the data plate.

Examples of improper installation

- Explosive and corrosive atmospheres
- Areas where the air temperature is very high and/or there is poor ventilation
- Outdoor without protection from weather conditions.

3.7 Use in water distribution networks for human consumption

If the unit is intended for water supply to people and/or animals:



WARNING:

It is prohibited to pump drinking water after use with other fluids.



WARNING:

Take appropriate measures during transport, installation and storage to prevent contamination from external substances.



WARNING:

Remove the unit from its packaging just before installation to prevent contamination from external substances.



WARNING:

After installation, run the unit for a few minutes with several users open in order to wash the inside of the system.

3.8 Special applications

Contact Xylem or the Authorised Distributor in the following cases:

- If liquids with a density and/or viscosity value exceeding that of water (such as water and glycol mixture) must be pumped
- If the pumped liquid is chemically treated (for example softened, deionized, demineralized etc.)
- Any situations different from those described, relating to the nature of the liquid
- Install the unit in the horizontal position.

4 Installation

4.1 Precautions

Before starting, make sure that the safety instructions shown in **Introduction and Safety** on page 5 have been fully read and understood.



DANGER:

All the hydraulic and electrical connections must be completed by a technician possessing the technical-professional requirements outlined in the current regulations.



DANGER: Potentially explosive atmosphere hazard

It is prohibited to start the unit in environments with potentially explosive atmospheres or with combustible dusts.



WARNING:

Always wear personal protective equipment.



WARNING:

Always use suitable working tools.



WARNING:

When selecting the place of installation and connecting the unit to the hydraulic and electric power supplies, strictly comply with current regulations.

When connecting the unit to a public or private aqueduct, or to a well for the supply of water for human and/or animal consumption, see **Use in water distribution networks for human consumption** on page 17.

4.2 Assembly of the motor

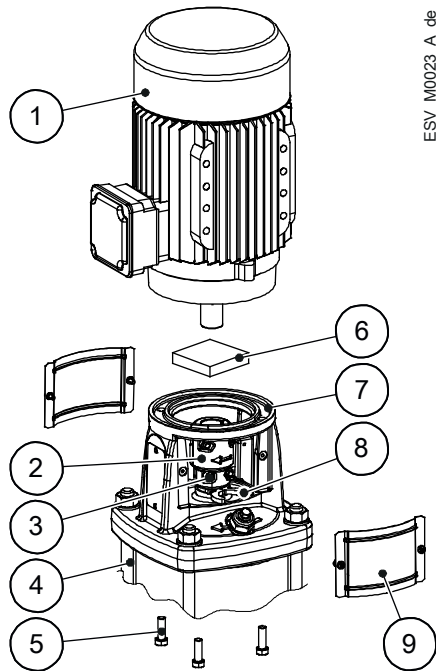

ESV_M0023_A_de

Position number	Description	Position number	Description
1	Motor	6	Pump shaft shim
2	Coupling	7	Adapter
3	Couple screw	8	Impeller stack shim
4	Pump	9	Coupling protection
5	Motor fixing screws		

1. Remove the protections and shim.

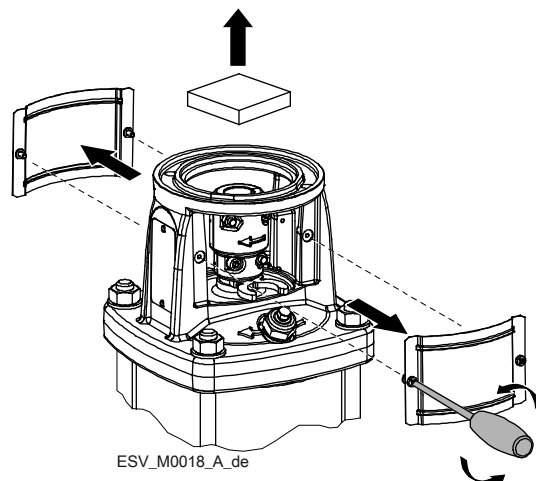

ESV_M0018_A_de

2. Loosen the couple screw.

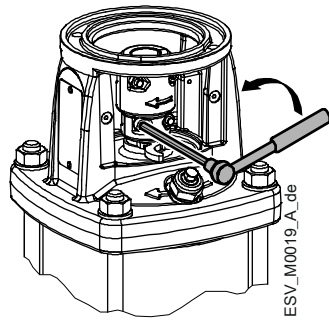

3. Secure the motor to the adapter with the bolts (not supplied).

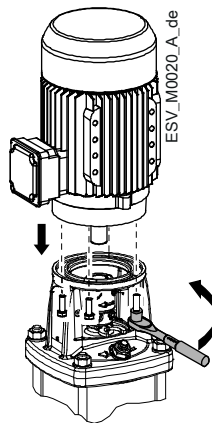

4. Tighten the couple screw.
5. Extract the shim placed between the adapter and coupling.

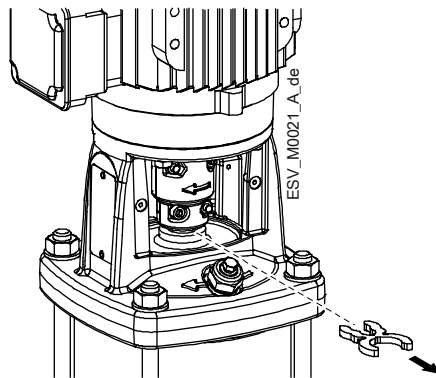

6. Reassemble the protections.

4.3 Mechanical installation

Install the unit on a concrete or metal foundation base sufficiently strong to ensure permanent and rigid support.

4.3.1 Installation area

1. Follow the provisions in **Operating environment** on page 40.
2. Place the unit in a raised position in relation to the floor.
3. Make sure that any leaks will not cause flooding to the installation area or submerge the unit.

Air clearance between a wall and the motor fan grille

- To ensure suitable ventilation: ≥ 100 mm (4 in)
- To permit inspection and removal of the motor: ≥ 300 mm (12 in)
- If the space available is any less, refer to the technical catalogue.

4.3.2 Permitted positions

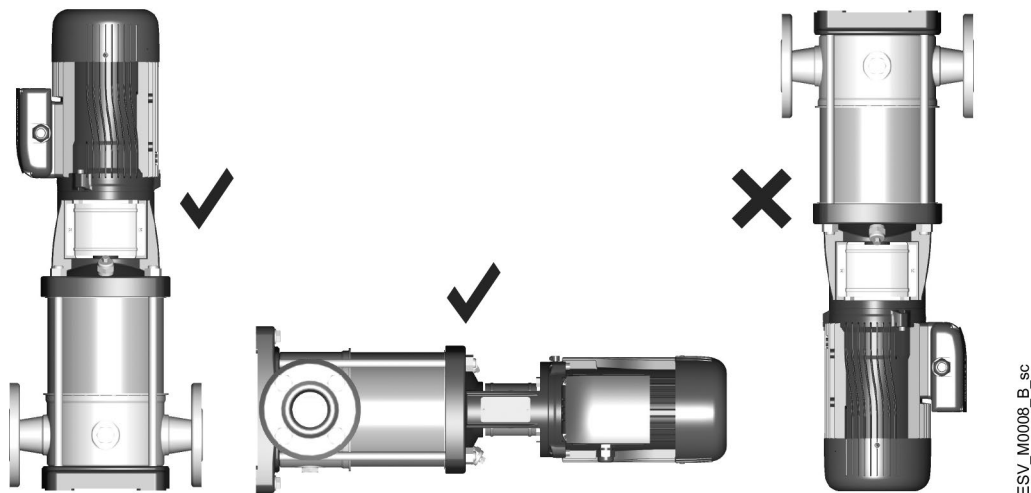

4.3.3 Installation on concrete foundation

Requirements

- The concrete must have a compression resistance of C12/15 and meet the requirements of exposure class XC1 according to EN 206-1
- Sizes must be appropriate for the sizes of the unit support plate, see **Fastening of the unit** on page 21
- The foundation weight must be ≥ 1.5 times the unit weight (≥ 5 times the weight of the unit if a quieter operation is required)
- The surface should be as flat and level as possible.

4.3.4 Fastening of the unit

1. If present, remove the plugs covering the suction and discharge ports.
2. Place the unit on the foundation.
3. Using a spirit level, make sure that the unit is level.
4. Align the suction and discharge ports to their piping.
5. Secure the unit with 4 bolts with resistance class 8.8 or higher; see the table.

Also see **Reducing vibrations** and **Hydraulic connection** on page 22.

ESV_MC0009_A_ph

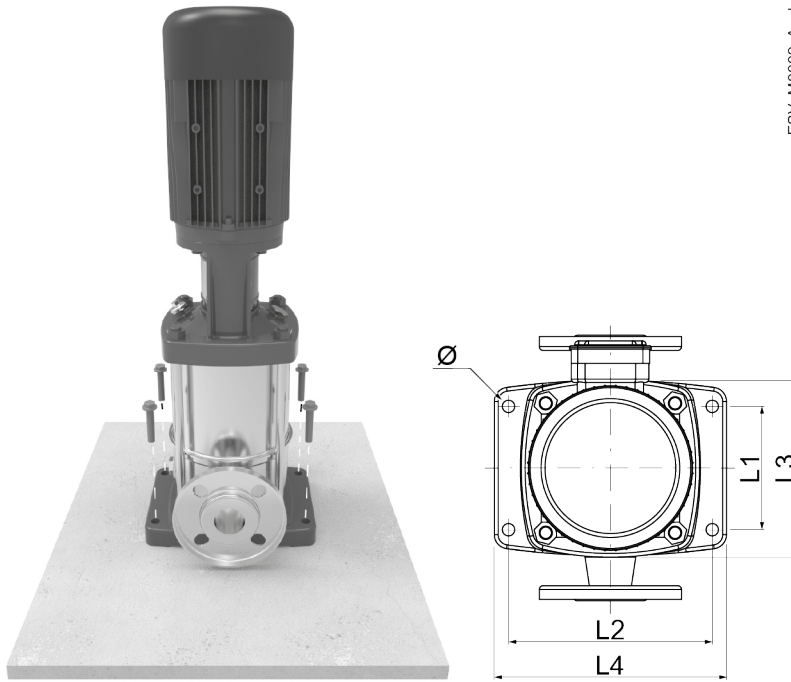

Model	L1, mm (in)	L2, mm (in)	L3, mm (in)	L4, mm (in)	Ø, mm (in)	Bolt size
1, 3, 5SV	100 (3,94)	180 (7,09)	150 (5,90)	210 (8,27)	13 (0,51)	M12
10,15, 22SV	130 (5,12)	215 (8,46)	185 (7,28)	245 (9,65)		
33SV	170 (6,69)	240 (9,45)	220 (8,66)	290 (11,41)	15 (0,59)	M14
46, 66, 92SV	190 (7,48)	265 (10,43)	240 (9,45)	315 (12,40)		
125SV	275 (10,82)	380 (14,96)	330 (12,99)	450 (17,72)	19 (0,75)	M18

4.3.5 Reducing vibrations

The engine and the flow of liquids in the piping can generate vibrations, which may be amplified from the possible incorrect installation of the unit and the piping. See **Hydraulic connection** on page 22.

4.4 Hydraulic connection



DANGER:

All the hydraulic and electrical connections must be completed by a technician possessing the technical-professional requirements outlined in the current regulations.



WARNING:

Piping must be sized to ensure safety at the maximum operating pressure.



WARNING:

Install appropriate seals between the unit couplings and the pipings.

4.4.1 Guidelines for the hydraulic system

Refer to the representative hydraulic diagrams; see the figures below.

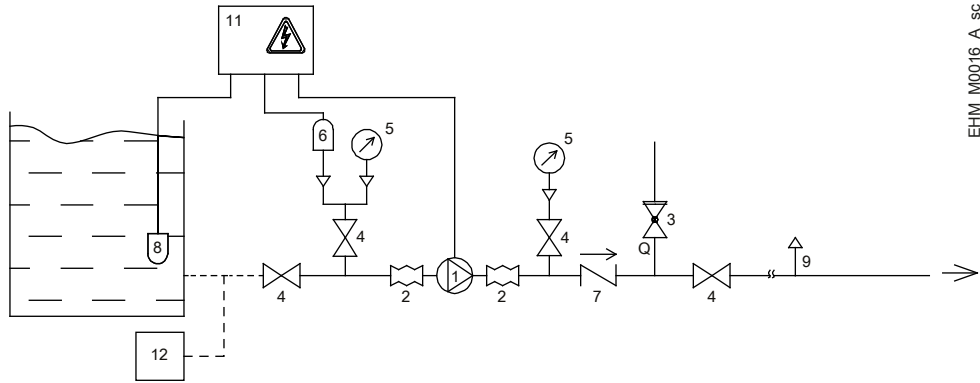

EHM_M0016_A_sc

Figure 1: Positive suction head installation

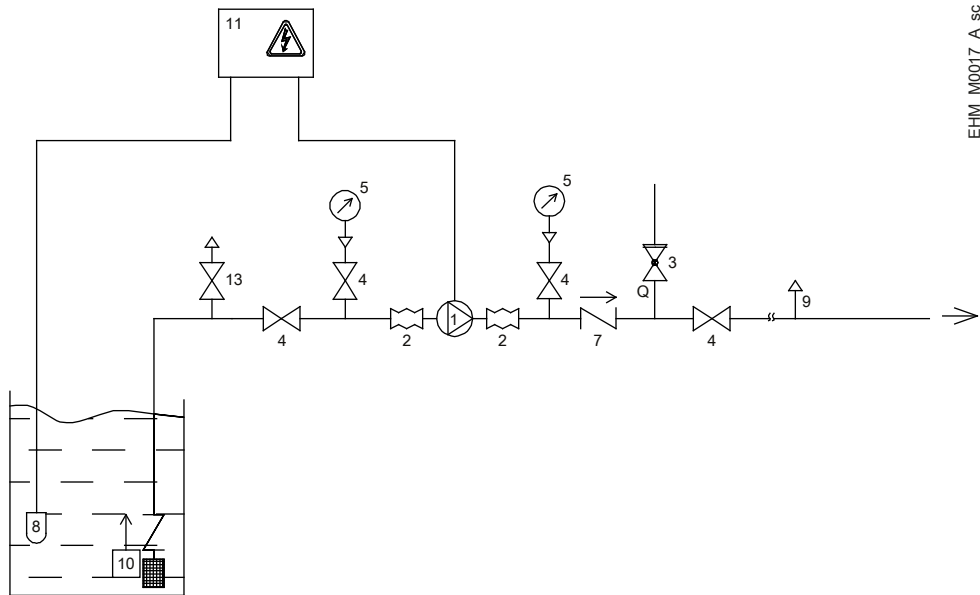

EHM_M0017_A_sc

Figure 2: Suction lift installation

Position number	Description	Position number	Description
1	Pump unit	8	Electrode probes or float
2	Anti-vibration joint	9	Automatic relief valve
3	Overpressure safety on-off valve	10	Foot check valve with filter
4	On-off valve	11	Electric panel
5	Pressure gauge	12	Pressurised circuit
6	Minimum pressure switch	13	Filling on-off valve
7	Check valve		

1. Do not install the unit at the lowest point of the system, to avoid the accumulation of sediments.
2. Install an automatic relief valve at the highest point of the system to eliminate air bubbles.
3. Remove any welding residues, deposits and impurities in the pipes that could damage the unit; install a filter if necessary.
4. Support the pipes independently to prevent them from weighing on the unit.

5. To reduce the transmission of vibrations between the unit and the system and vice versa, install:
 - anti-vibration joints on the suction and discharge sides of the unit
 - dampers between the unit and the surface on which it is installed.
6. In order to reduce flow resistance, the pipe on the suction side must be:
 - As short and as straight as possible
 - For the section connected to the unit, straight and without bottlenecks, covering a length equal to at least six times the diameter of the suction port
 - Wider than the suction port; if necessary, install an eccentric reducer that is horizontal on top
 - Without bends; if this cannot be avoided, bends of a radius as wide as possible
 - Without traps and 'goosenecks'
 - With on-off valves with a low specific flow resistance.

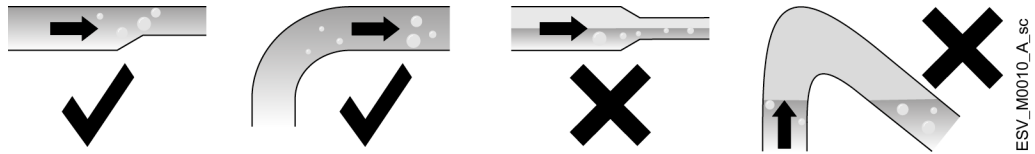

7. Install a check valve on the discharge side to prevent the liquid from flowing back into the pump unit when this is at standstill.
8. Install a pressure gauge (or a vacuum pressure gauge, in case of suction lift installation) on the suction side, and a pressure gauge on the discharge side, for checking the actual operating pressure of the pump unit.
9. To exclude the unit from the system for the purpose of maintenance, install:
 - An on-off valve on the suction side
 - An on-off valve on the discharge side, downstream the check valve and pressure gauge, also useful for regulating the flow rate.
10. On the suction side, install a device to prevent the absence of liquid (float or probes), or a minimum pressure device.
11. Sufficiently submerge the end of the suction pipe in the liquid, in order to prevent any air from penetrating through the suction vortex when the level is at the minimum
12. In case of suction lift installation, the suction pipe must have an increasing slope towards the unit exceeding 2%; to avoid air pockets; also install:
 - A foot check valve that guarantees full opening (full section)
 - A filling on-off valve to facilitate the removal of the air and priming.

4.4.2 Forces and torques applicable to the flanges

The table shows the maximum allowable forces and torques exerted by the piping on the flanges of the unit.

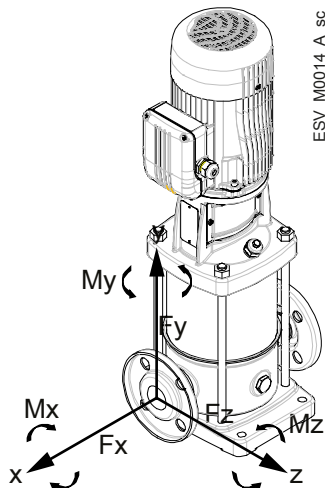

Model	DN, mm (in)	Forces, N (lbf)			Torques, Nm (lbf-in)		
		Fx	Fy	Fz	Mx	My	Mz
1, 3SV	25 (0,98)	200 (45)	180 (41)	230 (52)	240 (2124)	160 (1416)	190 (1682)
5SV	32 (1,26)	260 (59)	240 (54)	300 (68)	310 (2744)	210 (1859)	250 (2213)
10SV	40 (1,57)	330 (74)	300 (68)	370 (83)	390 (3452)	270 (2390)	310 (2744)
15, 22SV	50 (1,97)	450 (101)	400 (90)	490 (110)	420 (3718)	300 (2656)	340 (3010)
33SV	65 (2,56)	1800 (405)	1700 (382)	2000 (450)	1500 (13 276)	1050 (9294)	1200 (10 621)
46SV	80 (3,15)	2250 (506)	2050 (461)	2500 (562)	1600 (14 161)	1150 (10 179)	1300 (11 506)
66, 92SV	100 (3,94)	3000 (675)	2700 (607)	3350 (753)	1750 (15 489)	1250 (11 064)	1450 (12 834)
125SV	125 (4,92)	3700 (832)	3300 (742)	4100 (922)	2100 (18 587)	1500 (13 276)	1750 (15 489)

4.5 Electrical connection



DANGER:

All the hydraulic and electrical connections must be completed by a technician possessing the technical-professional requirements outlined in the current regulations.



DANGER: Electrical hazard

Before starting work, check that the unit is unplugged and that the pump unit, the control panel and the auxiliary control circuit cannot restart, even unintentionally.

NOTICE:

Before starting work, make sure that the general electric requirements and/or those of the firefighting systems (hydrants or sprinklers) comply with local regulations.

4.5.1 Ground



DANGER: Electrical hazard

Always connect the external protection conductor (ground) to the ground terminal before attempting to make any other electrical connections.



DANGER: Electrical hazard

Connect all the electrical accessories of the pump unit and motor to the ground.



DANGER: Electrical hazard

Check that the external protection conductor (ground) is longer than the phase conductors; In case of accidental disconnection of the unit from the phase conductors, the protection conductor must be the last one to detach itself from the terminal.



DANGER: Electrical hazard

Install suitable systems for protection against indirect contact, in order to prevent lethal electric shocks.

4.5.2 Guidelines for electrical connection

1. Check that the electrical leads are protected against:
 - High temperature
 - Vibrations
 - Collisions.
2. Check that the power supply line is provided with:
 - A short circuit protection device of appropriate size
 - A mains disconnection device with contact opening distance ensuring complete disconnection for overvoltage III category conditions.

4.5.3 Guidelines for the electrical control panel

NOTICE:

The electric panel must match the ratings on the unit data plate. Improper combinations could damage the motor.

1. Install appropriate devices for protecting the motor from overloads and short circuits:

Motor	Safety features
Single-phase	<ul style="list-style-type: none"> • Automatic reset thermal-ampere protection, in-built (motor protector) • From short circuit, by the installer: aM fuses (motor start-up), or thermal magnetic switch with C curve and $I_{cn} \geq 4.5 \text{ kA}$, or other similar device.
Three-phase	<ul style="list-style-type: none"> • Thermal, by the installer: trip class 10 A overload thermal relay + aM fuses (motor start-up), or start class 10 A motor protection thermal magnetic switch • From short circuit, by the installer: aM fuses (motor start-up), or thermal magnetic switch with C curve and $I_{cn} \geq 4.5 \text{ kA}$, or other similar device.

2. Fit a system for protection against dry running to which to connect a pressure switch, or a float, probes or other suitable devices.
3. On the suction side install:
 - A pressure switch, in the case of connection to the mains water supply
 - A float switch or probes, in the case of liquid drawn from a tank or basin.
4. If required, install phase failure sensitive thermal relays.

4.5.4 Guidelines for the motor

If using a motor other than the standard motor, check that a thermal protection device has been installed.



WARNING: Injuries hazard

The unit, equipped with a single-phase motor with automatic reset thermal overload protection, could restart inadvertently after it has cooled down: risk of physical injury.



WARNING:

The use of units with single-phase motors with automatic reset thermal protection for extinguishing fires and in pulverised water firefighting systems is forbidden.

NOTICE:

Only use dynamically balanced motors with half-sized key at the shaft end (IEC 60034-14), and with normal vibration rate (N).

NOTICE:

Only use single-phase or three-phase motors with sizes and powers in compliance with European standards.

NOTICE:

The mains voltage and frequency must match the specifications on the data plate.

Positioning of the motor terminal box

The position of the terminal box may be changed to facilitate the electric connections:

1. Remove the 4 bolts that secure the motor to the pump.
2. Rotate the motor in the desired position without removing the couplings.
3. Reposition and tighten the bolts at the torque indicated in the table.

Motor size	Bolt size	Torque, Nm (lbf-in)
71, 80	M6	6 (53)
90, 100, 112	M8	15 (133)
132	M12	50 (443)
160, 180, 200, 225, 250	M16	75 (664)

Electrical connection of the motor

1. Open the terminal box cover.
2. Connect the power supply conductors; see the figure below or the wiring diagram shown inside the cover.

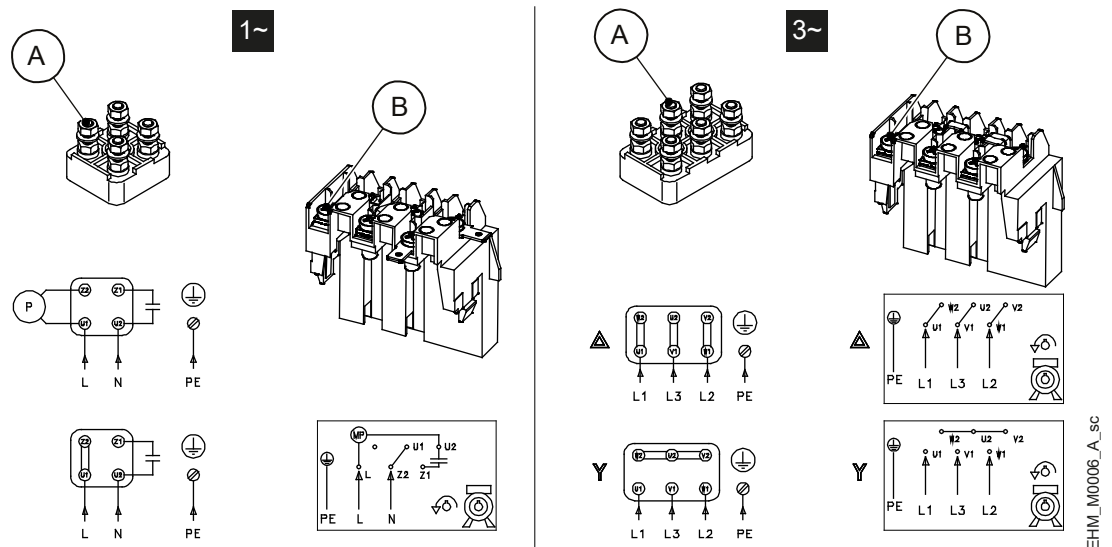

Position number	Bolt size	Torque, Nm (lbf-in)
A	M4	1,2 (11)
	M5	2,5 (22)
	M6	4,0 (35)
	M8	8,0 (71)
	M10	15,0 (133)
B	M4	1,2 (11)

3. Connect the protection conductor (ground), making sure that it is longer than the phase conductors.
4. Connect the phase leads.
5. Close the terminal box cover and tighten all the screws and cable glands.

Motor without automatic reset thermal overload protection

1. If the motor is used with full load, then set the value to the nominal current value on the data plate of the pump unit.
2. If the motor is used with partial load, then set the value of the operating current measured with a current pincer.
3. For three-phase motors with star-delta starting system, set the thermal relay downstream of the switching circuit at 58% of the rated or operating current.

4.5.5 Operation with frequency converter

The three-phase motors can be connected to a frequency converter for speed control.

- The converter exposes the insulation of the motor to a greater load, determined by the length of the connecting cable: observe the requirements of the Manufacturer of the frequency converter
- For applications requiring silent operation, install an outlet filter between the motor and the converter; a sinusoidal filter can reduce the noise even further
- The bearings of the motors, from size 315 S/M and up, are exposed to the risk of harmful currents: use electrically insulated bearings
- The conditions of installation must guarantee protection against voltage peaks between the terminals and/or dV/dt in the table:

Motor size	Voltage peak, V	dV/dt, V/μs
up to 90R (500 V)	< 650	< 2200
from 90R to 180R	< 1400	< 4600
over 180R	< 1600	< 5200

Otherwise, use a motor with reinforced insulation¹ and a sinusoidal filter.

¹ Available on request

5 Use and operation

5.1 Precautions



WARNING: Injuries hazard

Check that the protection devices of the coupling are installed, when applicable: risk of physical injury.



WARNING:

Make sure that the drained liquid cannot cause damage or injuries.



WARNING: Electrical hazard

Check that the unit is properly connected to the mains power supply.



WARNING: Injuries hazard

The unit, equipped with a single-phase motor with automatic reset thermal overload protection, could restart inadvertently after it has cooled down: risk of physical injury.



WARNING: Hot surface hazard

Be aware of the extreme heat generated by the unit.



WARNING:

It is prohibited to put combustible materials near the unit.

NOTICE:

Check that the shaft can turn smoothly.

NOTICE:

It is prohibited to operate the unit when dry, not primed and below the minimum rated flow rate.

NOTICE:

It is prohibited to operate the unit with the on-off valves on the suction and discharge sides closed.

NOTICE:

It is prohibited to use the unit in the case of cavitation.

NOTICE:

The unit must be filled and vented properly before it can be started.

NOTICE:

The maximum pressure delivered by the unit at the discharge side, determined by the pressure available on the suction side, must not exceed the maximum pressure (PN).

5.2 Filling - Priming



WARNING:

In the case of liquids that are excessively hot or cold, pay attention to the risk of injury.

5.2.1 Positive suction head installation

Models 1, 3 and 5SV

1. Close the on-off valves on the suction (A) and discharge (B) sides; see the figure below.
2. Loosen the drain plug (C).
3. Loosen the filling plug (D).
4. Slowly open the on-off valve (A) until the liquid regularly comes out from the hole; if necessary, loosen the plug further (D).
5. Tighten the plug (C).
6. Tighten the plug (D).
7. Open both the on-off valves slowly and fully.

Models 10, 15, 22, 33, 46, 66, 92 and 125SV

1. Close the on-off valves on the suction (A) and discharge (B) sides; see the figure below.
2. Loosen the filling plug (D).
3. Slowly open the on-off valve (A) until the liquid regularly comes out from the hole; if necessary, loosen the plug further (D).
4. Tighten the plug (D).
5. Open both the on-off valves slowly and fully.

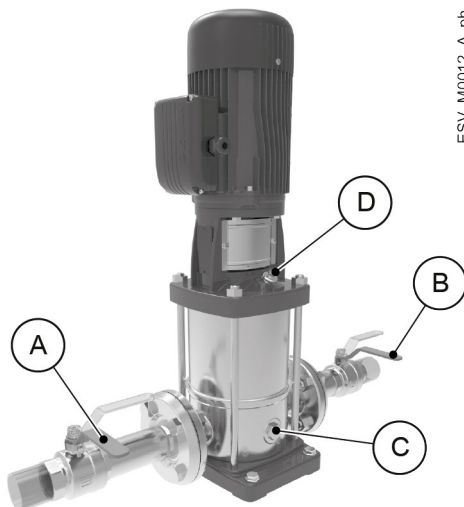

5.2.2 Suction lift installation

Models 1, 3 and 5SV

1. Open the on-off valves on the suction (A) and discharge (B) sides; see the figure below.
2. Loosen the drain plug (C).
3. Remove the filling plug (D).
4. Fill the pump unit until the liquid comes out of the hole.
5. Tighten the plug (C).
6. Close the plug (D).
7. Slowly fully open the on-off valve on the discharge side.

Models 10, 15, 22, 33, 46, 66, 92 and 125SV

1. Open the on-off valves on the suction (A) and discharge (B) sides; see the figure below.
2. Remove the filling plug (D).
3. Fill the pump unit until the liquid comes out of the hole.
4. Close the plug (D).
5. Slowly fully open the on-off valve on the discharge side.

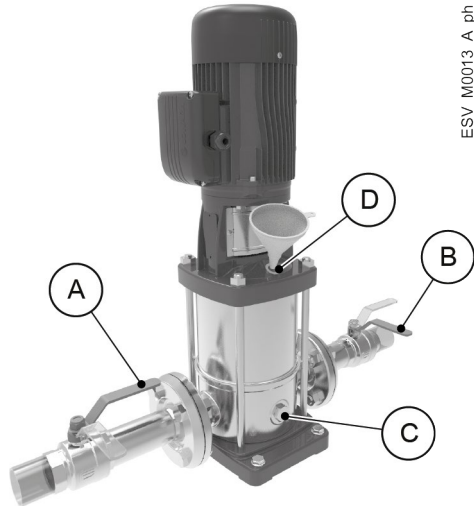

5.3 Rotation sense check (three-phase motors)

Before starting the unit:

NOTICE:

Check that the shaft can turn smoothly.

1. Locate the arrow on the adapter, the coupling or the cover, to determine the correct direction of rotation of the motor.
2. Start the unit.
3. Check the direction of rotation through the coupling protection, or through the motor cover.
4. Stop the unit.



5.3.1 Wrong rotation direction

1. Disconnect the power supply.
2. Invert two of the three wires of the power supply cord.

5.4 Start-up

NOTICE:

It is prohibited to operate the unit with the discharge side on-off valve closed or at zero flow rate: this can cause the liquid to overheat and damage the unit.

NOTICE:

If there is a risk of the unit running at a flow rate below the minimum expected, install a bypass circuit.

NOTICE:

Check that the shaft can turn smoothly.

1. Check that all the operations indicated in **Filling - Priming** on page 30 and in **Rotation sense check (three-phase motors)** on page 31 have been completed correctly.
2. Shut off the discharge on-off valve almost completely.
3. Fully open the suction on-off valve.
4. Start the unit.
5. Gradually open the discharge on-off valve until half open.
6. Wait a few minutes and then fully open the discharge on-off valve.

After the start-up procedure, with the pump unit in operation, check that:

- No liquid is leaking from the unit or pipes
 - The maximum pressure of the unit at the discharge, determined by the available suction pressure, must not exceed the maximum pressure (PN)
 - The current absorbed is within the rated limits (calibrate the thermal overload protection of the motor)
 - There is no unwanted noise or vibrations
 - At zero flow rate, the pressure at the discharge corresponds to the expected nominal pressure
 - No vortexes can occur at the end of the suction pipe, at the point of the foot check valve (suction lift installation).
-

NOTICE:

If the units does not deliver the required pressure, repeat the operations in **Filling - Priming**.

WARNING:

After startup, run the unit for a few minutes with several users open in order to wash the inside of the system.



Settling of the mechanical seal

The pumped liquid lubricates the seal faces of the mechanical seal; under normal conditions, a small amount of liquid may leak out. When the unit is run for the first time, or immediately after the seal is replaced, more liquid may temporarily leak out. To help the seal settle and to reduce leaking:

1. Close and open the on-off valve on the discharge side two or three times with the unit running.
2. Stop and start the unit two or three times.

5.5 Stopping

1. Shut the on-off valve located on the discharge line.
2. Stop the pump unit and check that the motor slows down gradually.
3. Gradually re-open the on/off valve and check that the motor remains still.

6 Maintenance

6.1 Precautions

Before starting, make sure that the instructions shown in **Introduction and Safety** on page 5 have been fully read and understood.



WARNING:

Maintenance must be done by a technician possessing the technical-professional requirements outlined in the current regulations.



WARNING:

Always wear personal protective equipment.



WARNING:

Always use suitable working tools.



WARNING:

In the case of liquids that are excessively hot or cold, pay attention to the risk of injury.



DANGER: Electrical hazard

Before starting work, check that the unit is unplugged and that the pump unit, the control panel and the auxiliary control circuit cannot restart, even unintentionally.



DANGER: Electrical hazard

If the unit is connected to the frequency converter, disconnect the mains power supply and wait at least 10 minutes for the residual current to dissipate.

6.2 Maintenance every 4000 hours of operation, or every year

When the first of the two limits is reached:

1. Measure the pressure at zero flow rate and compare it with the pressure measured during initial start-up; if the pressure has decreased by more than 15%, check the condition of impeller, pump body and wear rings.
2. Check the unit for unwanted noise and vibrations.
3. Check that there is no liquid leaking from the unit or pipes.
4. Check that all the screws and bolts of the unit and pipes are properly fastened.
5. Check that the insulation resistance of the motor is greater than 500 M Ω , applying a test voltage of 500 Vdc for 1 minute.
6. Check the terminal board of the motor for any signs of overheating and arc flashes.
7. Check the condition of the motor's cooling fan and clean it.
8. Check the integrity of the power cable.

6.3 Long periods of inactivity

1. Close the on-off valve on the suction side.
2. Completely empty the unit.
3. Protect the unit against freezing.
4. Before restarting the unit, check that the shaft is rotating freely, without mechanical impediments.

6.4 Tightening torques of the threaded connections

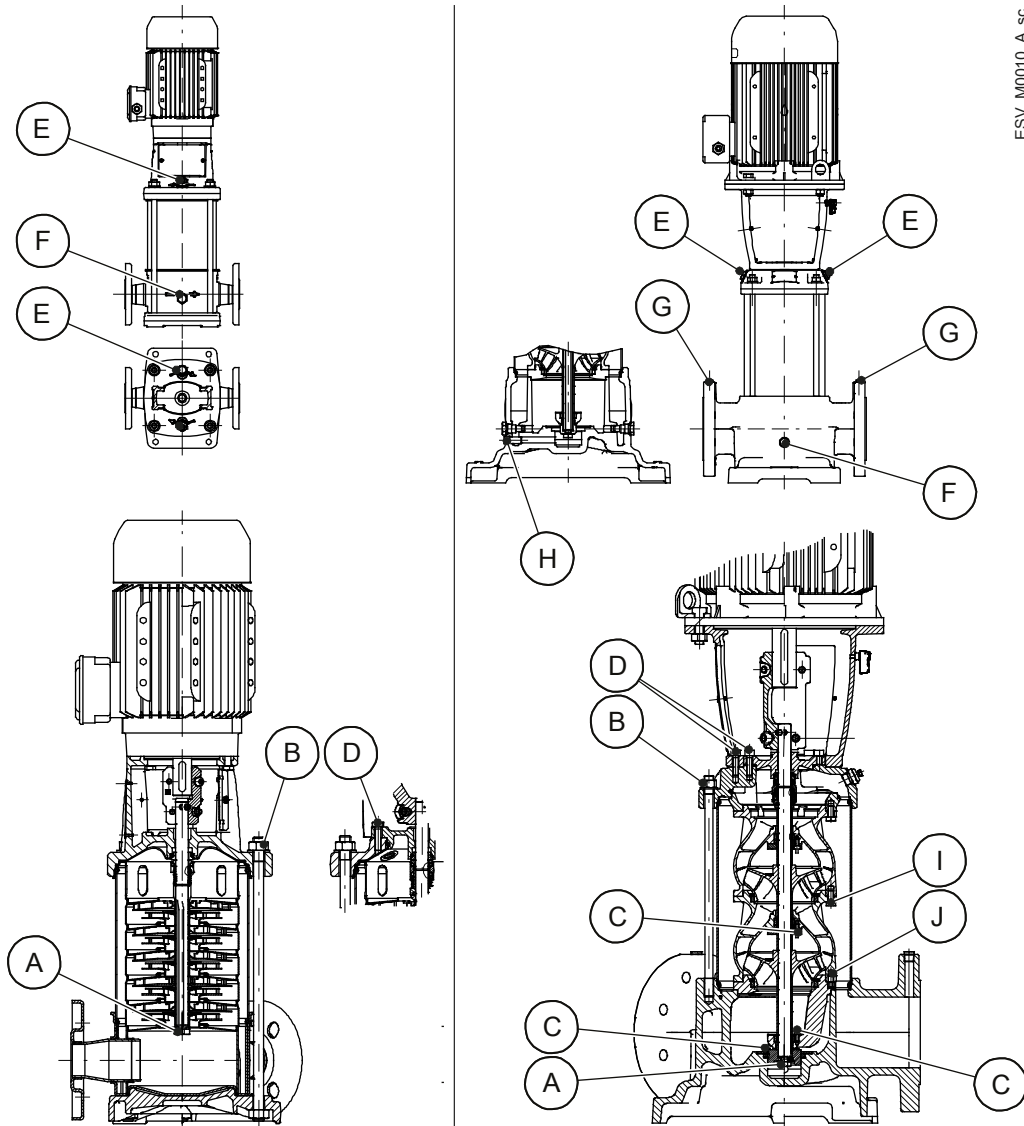

ESV_M0010_A_sc

Table 1: Tightening torques of the threaded fittings, Nm (lbf in)

Model	A	B	C	D	E, F	G	H	I	J
1, 3, 5SV	M8	M12	-	-	G 3/8"	-	-	-	-
	20 (177)	25 (220)	-	-	25 (220)	-	-	-	-
10, 15, 22SV	M10	M14	-	M8	G 3/8"	-	-	-	-
	35 (310)	30 (265)	-	20 (177)	25 (220)	-	-	-	-
33, 46, 66, 92SV	M12	M16	M6	M10	G 1/2"	R 3/8"	M16	-	-
	60 (530)	60 (530)	8 (71)	35 (310)	40 (354)	40 (354)	40 (354)	-	-
125SV	M12	M16	M6	M10	G 1/2"	R 3/8"	M16	M10	M10
	65 (575)	60 (530)	8 (71)	35 (310)	30 (265)	40 (354)	40 (354)	35 (310)	15 (133)

6.5 Spare parts ordering

Identify the spare parts with the product codes directly on the site www.lowara.com/spark. Contact Xylem or the Authorised Distributor for technical information.

7 Troubleshooting

7.1 Precautions



WARNING:

Maintenance must be done by a technician possessing the technical-professional requirements outlined in the current regulations.



WARNING:

Observe the safety instructions given in Use and operation and Maintenance.



WARNING:

If a fault cannot be corrected or is not mentioned, contact Xylem or the Authorised Distributor.

7.2 The unit does not start

Cause	Remedy
Power supply cut off	Restore the power supply
The thermal overload protection of the motor has been triggered	Reset the thermal overload protection on the control panel or the unit
The device that detects the absence of liquid or minimum pressure has been triggered	Top up the liquid or restore minimum pressure
The capacitor, if present, is faulty	Replace the capacitor
Control panel faulty	Check and repair or replace the control panel
Motor (coil) faulty	Check and repair or replace the motor

7.3 The differential protection device (RCD) is activated

Cause	Remedy
Motor leaking	Check and repair or replace the motor
Unsuitable type of differential	Check the type of differential

7.4 The thermal overload protection triggers or the fuses trip

The motor thermal overload protection triggers or the fuses trip when the unit starts.

Cause	Remedy
It is calibrated at a value too low in relation to the rated current of the motor	Recalibrate
Missing power supply phase	Check the power supply and restore the phase
Loose and/or faulty connections of the thermal overload protection	Tighten or replace the clamps and terminals
Loose and/or incorrect and/or faulty (star-delta) connections in the terminal board of the motor	Tighten or replace the clamps and terminals
Motor (coil) faulty	Check and repair or replace the motor
Pump unit mechanically seized	Check and repair the pump unit
Check valve faulty	Replace the check valve
Foot check valve faulty	Replace the foot check valve

7.5 The thermal overload protection triggers

The motor thermal overload protection triggers occasionally, or after the unit has been running for a few minutes.

Cause	Remedy
It is calibrated at a value too low in relation to the rated current of the motor	Recalibrate
Input voltage outside the rated limits	Make sure the voltage values are correct
Unbalanced input voltage	Make sure the voltage of the three phases is balanced
Incorrect working curve (flow rate greater than the maximum permitted flow rate)	Reduce the required flow rate
Liquid too dense, presence of solid or fibrous substances (unit overloaded)	<ul style="list-style-type: none"> • Reduce the density of the liquid and/or • Remove the solid substances and/or • Increase the size of the motor
Room temperature too high, exposure to sunlight	<ul style="list-style-type: none"> • Lower the temperature at the point of the thermal overload protection and/or • Protect against direct sunlight
Unit faulty	Send the unit to an authorised workshop for testing

7.6 The motor becomes excessively hot

Cause	Remedy
Room temperature outside the rated limits	Lower the room temperature
Cooling fan of the motor clogged or damaged	Clean or replace the cooling fan
The unit starts up too frequently	See the section: The unit produces excessive noise and/or vibrations
The frequency converter, if present, has not been calibrated properly	See the frequency converter manual

7.7 The unit runs but there is little or no flow rate

Cause	Remedy
Motor turns in the wrong direction	Check the direction of rotation and change it if necessary
Incorrect priming (there are air bubbles in the suction pipe or in the unit)	Repeat the priming procedure
Cavitation	Increase the NPSH ² available in the system
Check valve locked in closed or partially closed position	Replace the check valve
Foot check valve locked in closed or partially closed position	Replace the foot check valve
Discharge pipe throttled	Remove the throttling
Piping and/or unit clogged	Remove the clogging

7.8 When switched off, the unit turns in the opposite direction

Cause	Remedy
Check valve faulty	Replace the check valve
Foot check valve faulty	Replace the foot check valve

² Net Positive Suction Head

7.9 The unit produces excessive noise and/or vibrations

Cause	Remedy
Cavitation	Increase the NPSH ³ available in the system
Unsuitable anchoring to the ground	Check the anchoring to the ground
Resonance	Check the installation
Anti-vibration joints not installed	Install anti-vibration joints on the suction and discharge sides of the unit
Foreign bodies in the unit	Remove the foreign bodies
Motor bearings worn or faulty	Replace the motor bearings
The unit does not turn freely due to a mechanical fault	Send the unit to an authorised workshop for testing

7.10 The unit starts up too frequently (automatic start/stop)

Cause	Remedy
Incorrect priming (there are air bubbles in the suction pipe or in the unit)	Repeat the priming procedure
Check valve locked in closed or partially closed position	Replace the check valve
Foot check valve locked in closed or partially closed position	Replace the foot check valve
Starter (pressure switch, sensor, etc.) set incorrectly, or faulty	Adjust or replace the starter
Expansion vessel <ul style="list-style-type: none"> • no pre-charge, or • undersized, or • not installed 	<ul style="list-style-type: none"> • Pre-charge the expansion vessel, or • replace the expansion vessel with another suitable one, or • install an expansion vessel
Oversized unit	Contact Xylem or the Authorised Distributor

7.11 The unit never stops (automatic start/stop)

Cause	Remedy
The required flow rate is greater than the one expected	Reduce the required flow rate
Discharge pipe leaking	Eliminate the leaks
Motor turns in the wrong direction	Check the direction of rotation and change it if necessary
Pipes, on-off valves or filter clogged with impurities	Remove the impurities
Starter (pressure switch, sensor, etc.) set incorrectly, or faulty	Adjust or replace the starter
The unit runs but there is little or no flow rate	See the section: The thermal overload protection triggers

³ Net Positive Suction Head

7.12 The unit is leaking

Cause	Remedy
Worn mechanical seal	Replace the mechanical seal, or Fit a mechanical seal with harder seal faces
Mechanical seal damaged due to thermal shock (presence of air bubbles in the unit)	Replace the mechanical seal
Defective mechanical seal	Replace the mechanical seal
Mechanical seal damaged due to temperature of the liquid outside the rated limits	Replace the mechanical seal with another of a suitable make
Mechanical seal damaged due to chemical incompatibility with the liquid	Replace the mechanical seal with one of a make chemically compatible with the pumped liquid

7.13 The frequency converter is in error mode or turned off

The frequency converter (if present) is in error mode or turned off

Cause	Remedy
See the frequency converter manual	See the frequency converter manual

8 Technical Information

8.1 Operating environment

Non-aggressive and non-explosive atmosphere.

Temperature

From 0 to 40°C (32÷104°F), unless otherwise indicated on the data plate of the electric motor.

Relative air humidity

< 50% at 40°C (104°F).

NOTICE:

If the humidity exceeds the stated limits, contact Xylem or the Authorised Distributor.

Elevation

< 1000 m (3280 ft) above sea level.

NOTICE: Danger of motor overheating

If the unit is exposed to temperatures or installed at an altitude greater than those stated, reduce the power output of the motor according to the coefficients reported in the table. Otherwise, replace the motor with a more powerful one.

Altitude m (ft)	Power reduction coefficient
1000÷1500 (3300÷4900)	0.97
1500÷2000 (4900÷6600)	0.95

8.2 Temperature of pumped liquid

The table shows the permitted liquid temperatures according to the mechanical seal.

Seal material	Minimum and maximum temperature, °C (°F)
EPDM	-30÷120 (-22÷248)
FKM (FPM)	-10÷120 (14÷248)
PTFE	0÷120 (32÷248)

8.3 Maximum head

The tables show the maximum pressure head according to the model.

50 Hz @2900 min⁻¹ motors

Model	m	ft	Model	m	ft	Model	m	ft	Model	m	ft
1SV02F003	12	40	5SV12F022	91	298	22SV14F150T	217	711	46SV8G300T	213	699
1SV03F003	18	59	5SV13F022	98	323	22SV17F185T	264	865	46SV9/2AG300T	225	738
1SV04F003	24	78	5SV14F022	106	347	33SV1/1AG022T	17	57	46SV9G370T	241	790
1SV05F003	29	96	5SV15F022	113	371	33SV1G030T	24	78	46SV10/2AG370T	253	829
1SV06F003	35	114	5SV16F022	121	395	33SV2/2AG040T	35	115	46SV10G370T	268	878
1SV07F003	40	132	5SV18F030T	136	446	33SV2/1AG040T	41	134	46SV11/2AG450T	280	920
1SV08F005	48	158	5SV21F030T	158	518	33SV2G055T	48	157	46SV11G450T	296	969

Model	m	ft	Model	m	ft	Model	m	ft	Model	m	ft
1SV09F005	54	176	5SV23F040T	174	572	33SV3/2AG055T	58	189	46SV12/2AG450T	307	1008
1SV10F005	59	195	5SV25F040T	189	621	33SV3/1AG075T	65	212	46SV12G450T	322	1056
1SV11F005	65	214	5SV28F040T	212	694	33SV3G075T	72	235	46SV13/2AG450T	333	1091
1SV12F007	73	240	5SV30F055T	227	745	33SV4/2AG075T	82	269	66SV1/1AG040T	24	78
1SV13F007	79	260	5SV33F055T	249	818	33SV4/1AG110T	89	292	66SV1G055T	29	96
1SV15F007	91	298	10SV01F007	12	39	33SV4G110T	96	315	66SV2/2AG075T	48	156
1SV17F011	105	345	10SV02F007	24	77	33SV5/2AG110T	106	348	66SV2/1AG110T	54	178
1SV19F011	117	384	10SV03F011	36	117	33SV5/1AG110T	113	370	66SV2G110T	60	198
1SV22F011	135	442	10SV04F015	48	156	33SV5G150T	120	395	66SV3/2AG150T	78	257
1SV25F015	153	501	10SV05F022	60	197	33SV6/2AG150T	131	430	66SV3/1AG150T	85	278
1SV27F015	164	539	10SV06F022	72	236	33SV6/1AG150T	139	456	66SV3G185T	91	300
1SV30F015	182	596	10SV07F030T	84	274	33SV6G150T	146	478	66SV4/2AG185T	109	357
1SV32F022	197	647	10SV08F030T	95	313	33SV7/2AG150T	156	512	66SV4/1AG220T	115	378
1SV34F022	209	686	10SV09F040T	106	349	33SV7/1AG185T	163	536	66SV4G220T	122	399
1SV37F022	226	741	10SV10F040T	118	387	33SV7G185T	170	559	66SV5/2AG300T	139	456
3SV02F003	15	49	10SV11F040T	130	425	33SV8/2AG185T	181	593	66SV5/1AG300T	146	478
3SV03F003	22	72	10SV13F055T	156	512	33SV8/1AG185T	187	615	66SV5G300T	152	499
3SV04F003	29	95	10SV15F055T	180	589	33SV8G220T	194	637	66SV6/2AG300T	170	556
3SV05F005	37	122	10SV17F075T	205	673	33SV9/2AG220T	202	663	66SV6/1AG300T	176	577
3SV06F005	44	146	10SV18F075T	217	712	33SV9/1AG220T	210	690	66SV6G370T	182	598
3SV07F007	53	172	10SV20F075T	241	789	33SV9G220T	217	711	66SV7/2AG370T	200	656
3SV08F007	60	197	10SV21F110T	254	832	33SV10/2AG220T	226	743	66SV7/1AG370T	206	677
3SV09F011	68	222	15SV01F011	14	46	33SV10/1AG300T	235	769	66SV7G450T	213	698
3SV10F011	75	246	15SV02F022	29	94	33SV10G300T	242	793	66SV8/2AG450T	230	756
3SV11F011	82	270	15SV03F030T	43	142	33SV11/2AG300T	252	827	66SV8/1AG450T	237	777
3SV12F011	90	294	15SV04F040T	58	192	33SV11/1AG300T	259	850	66SV8G450T	243	798
3SV13F015	98	322	15SV05F040T	73	239	33SV11G300T	266	872	92SV1/1AG055T	25	80
3SV14F015	106	346	15SV06F055T	88	287	33SV12/2AG300T	276	905	92SV1G075T	34	110
3SV16F015	120	393	15SV07F055T	102	334	33SV12/1AG300T	283	928	92SV2/2AG110T	49	162
3SV19F022	144	473	15SV08F075T	117	385	33SV12G300T	290	951	92SV2G150T	68	222
3SV21F022	159	523	15SV09F075T	132	433	33SV13/2AG300T	301	986	92SV3/2AG185T	82	270
3SV23F022	174	571	15SV10F110T	148	485	33SV13/1AG300T	307	1007	92SV3G220T	102	335
3SV25F022	189	618	15SV11F110T	162	532	46SV1/1AG030T	20	64	92SV4/2AG300T	116	380
3SV27F030T	204	671	15SV13F110T	191	628	46SV1G040T	27	89	92SV4G300T	133	437
3SV29F030T	219	719	15SV15F150T	222	729	46SV2/2AG055T	39	127	92SV5/2AG370T	149	489
3SV31F030T	234	767	15SV17F150T	252	825	46SV2G075T	53	173	92SV5G370T	166	546
3SV33F030T	249	815	22SV01F011	15	48	46SV3/2AG110T	65	212	92SV6/2AG450T	183	601
5SV02F003	15	49	22SV02F022	30	100	46SV3G110T	81	265	92SV6G450T	201	659
5SV03F005	22	72	22SV03F030T	45	149	46SV4/2AG150T	92	303	92SV7/2AG450T	217	711
5SV04F005	30	98	22SV04F040T	61	200	46SV4G150T	107	352	125SV1G075T	28	91
5SV05F007	38	125	22SV05F055T	76	249	46SV5/2AG185T	117	385	125SV2G150T	54	177
5SV06F011	45	149	22SV06F075T	93	306	46SV5G185T	135	441	125SV3G220T	81	265
5SV07F011	53	173	22SV07F075T	109	356	46SV6/2AG220T	144	471	125SV4G300T	108	353

Model	m	ft	Model	m	ft	Model	m	ft	Model	m	ft
5SV08F011	60	197	22SV08F110T	125	409	46SV6G220T	161	528	125SV5G370T	135	441
5SV09F015	68	223	22SV09F110T	140	460	46SV7/2AG300T	171	562	125SV6G450T	161	530
5SV10F015	76	248	22SV10F110T	155	510	46SV7G300T	189	619	125SV7G550T	188	618
5SV11F015	83	272	22SV12F150T	186	611	46SV8/2AG300T	198	650	125SV8/2AG550T	212	694

50 Hz @1450 min⁻¹ motors

Model	m	ft	Model	m	ft	Model	m	ft	Model	m	ft
1SV02F0024T	3	10	5SV21F0034T	38	126	22SV12F0224T	46	151	66SV2G0154T	15	49
1SV05F0024T	8	25	5SV25F0054T	45	149	22SV14F0224T	54	177	66SV3G0224T	22	73
1SV08F0024T	12	40	5SV28F0054T	52	170	22SV17F0304T	65	214	66SV4G0304T	30	97
1SV11F0024T	17	55	5SV33F0074T	61	198	33SV3/2AG0114T	14	47	66SV5G0404T	38	123
1SV15F0024T	23	74	10SV03F0054T	9	30	33SV4/1AG0114T	22	72	66SV6G0404T	45	147
1SV19F0024T	29	94	10SV04F0054T	12	39	33SV5G0154T	29	96	66SV7G0554T	53	173
1SV22F0024T	33	109	10SV06F0054T	18	59	33SV6G0224T	36	118	66SV8G0554T	60	197
1SV27F0024T	40	132	10SV08F0054T	24	77	33SV7G0224T	42	136	92SV1G0114T	8	27
1SV30F0024T	44	146	10SV10F0054T	29	95	33SV8G0304T	48	157	92SV2G0224T	16	53
1SV34F0024T	50	164	10SV13F0074T	38	124	33SV9G0304T	53	175	92SV3G0304T	24	80
1SV37F0024T	54	178	10SV15F0074T	44	145	33SV10G0304T	59	194	92SV4G0404T	33	108
3SV02F0024T	4	12	10SV17F0114T	50	163	33SV11G0404T	66	216	92SV5G0554T	42	136
3SV05F0024T	10	31	10SV19F0114T	55	181	33SV12G0404T	72	235	92SV6G0554T	50	162
3SV08F0024T	15	50	10SV21F0114T	63	206	33SV13G0404T	77	253	92SV7G0754T	58	190
3SV11F0024T	21	68	15SV03F0054T	11	35	46SV2G0114T	13	43	92SV8G0754T	66	216
3SV14F0024T	26	86	15SV05F0054T	18	58	46SV3G0154T	20	65	125SV1G0114T	7	23
3SV19F0024T	33	109	15SV07F0074T	25	81	46SV4G0224T	26	86	125SV2G0224T	14	44
3SV23F0024T	42	138	15SV09F0114T	33	108	46SV5G0224T	33	107	125SV3/3BG0224T	18	57
3SV27F0034T	50	163	15SV11F0114T	40	132	46SV6G0304T	39	129	125SV4/4BG030T	23	76
3SV33F0034T	60	198	15SV13F0154T	48	156	46SV7G0304T	46	149	125SV5/5AG040T	31	103
5SV03F0024T	6	19	15SV15F0154T	55	180	46SV8G0404T	53	172	125SV6G055T	40	133
5SV06F0024T	11	37	15SV17F0224T	63	205	46SV9G0404T	59	193	125SV7G075T	47	155
5SV09F0024T	17	55	22SV04F0054T	15	49	46SV10G0554T	66	217	125SV8G075T	54	177
5SV12F0024T	22	73	22SV06F0114T	23	74	46SV11G0554T	73	238	-	-	-
5SV15F0034T	28	90	22SV08F0114T	31	101	46SV12G0554T	79	259	-	-	-
5SV18F0034T	33	109	22SV10F0154T	39	127	66SV1G0114T	7	24	-	-	-

60 Hz @3500 min⁻¹ motors

Model	m	ft	Model	m	ft	Model	m	ft	Model	m	ft
1SV02F0036	17	57	5SV05F0156	55	180	22SV01F0226	22,2	22,2	46SV4/2AG2206T	134	440
1SV03F0036	26	84	5SV06F0156	66	216	22SV02F0406T	44,5	44,5	46SV4/1AG3006T	144	473
1SV04F0036	34	111	5SV07F0226	77	251	22SV03F0556T	66,7	66,7	46SV4G3006T	156	511
1SV05F0056	44	143	5SV08F0226	87	286	22SV04F0756T	89	89	46SV5/2AG3006T	172	563
1SV06F0056	52	171	5SV09F0226	98	321	22SV05F1106T	111,5	111,5	46SV5/1AG3006T	183	601
1SV07F0076	61	200	5SV10F0306T	109	358	22SV06F1106T	133,5	133,5	46SV5G3706T	195	638
1SV08F0076	69	228	5SV11F0306T	120	393	22SV07F1506T	156,4	156,4	46SV6/2AG3706T	211	691
1SV09F0076	78	256	5SV12F0306T	131	428	22SV08F1506T	178,6	178,6	46SV6/1AG3706T	222	728
1SV10F0116	88	287	5SV13F0406T	143	468	22SV09F1856T	201,3	201,3	46SV6G3706T	234	766

Model	m	ft	Model	m	ft	Model	m	ft	Model	m	ft
1SV11F0116	96	316	5SV14F0406T	153	503	22SV10F1856T	223,5	223,5	46SV7/2AG4506T	250	821
1SV12F0116	105	344	5SV15F0406T	164	539	33SV1/1AG0306T	24,5	24,5	46SV7/1AG4506T	262	859
1SV13F0116	113	371	5SV16F0406T	175	574	33SV1G0556T	34,5	34,5	46SV7G4506T	273	897
1SV15F0156	131	430	5SV17F0556T	186	612	33SV2/2AG0556T	49,6	49,6	66SV1/1AG0756T	31	103
1SV17F0156	148	487	5SV19F0556T	208	682	33SV2/1AG0756T	59,6	59,6	66SV1G1106T	44	144
1SV18F0226	158	520	5SV21F0556T	230	753	33SV2G1106T	69,4	69,4	66SV2/2AG1506T	65	212
1SV20F0226	176	576	5SV23F0556T	251	823	33SV3/2AG1106T	86	86	66SV2/1AG1856T	75	246
1SV22F0226	193	633	10SV01F0076	17	56	33SV3/1AG1106T	95	311	66SV2G1856T	85	280
1SV24F0226	210	689	10SV02F0156	34	112	33SV3G1506T	104	342	66SV3/2AG2206T	107	350
1SV26F0226	227	746	10SV03F0226	52	170	33SV4/2AG1506T	120	393	66SV3/1AG3006T	117	385
1SV28F0306	245	805	10SV04F0306T	69	227	33SV4/1AG1506T	129	423	66SV3G3006T	128	419
3SV02F0036	21	70	10SV05F0406T	87	286	33SV4G1856T	138	454	66SV4/2AG3706T	149	489
3SV03F0056	33	107	10SV06F0406T	105	343	33SV5/2AG1856T	156	511	66SV4/1AG3706T	159	522
3SV04F0076	43	142	10SV07F0556T	122	401	33SV5/1AG2206T	164	538	66SV4G3706T	169	555
3SV05F0116	55	179	10SV08F0556T	139	457	33SV5G2206T	173	568	66SV5/2AG4506T	192	630
3SV06F0116	65	215	10SV09F0756T	157	516	33SV6/2AG2206T	189	620	66SV5/1AG4506T	202	663
3SV07F0116	76	250	10SV10F0756T	175	573	33SV6/1AG3006T	199	654	66SV5G4506T	212	696
3SV08F0156	87	286	10SV11F0756T	192	630	33SV6G3006T	209	684	92SV1/1AG1106T	36	119
3SV09F0156	98	321	10SV13F1106T	227	744	33SV7/2AG3006T	225	737	92SV1G1506T	50	162
3SV10F0226	110	359	10SV15F1106T	261	857	33SV7/1AG3006T	234	767	92SV2/2AG1856T	70	229
3SV11F0226	120	395	15SV01F0156	20	65	33SV7G3006T	243	798	92SV2/1AG2206T	84	274
3SV12F0226	131	430	15SV02F0306T	42	137	33SV8/2AG3706T	259	851	92SV2G3006T	98	321
3SV13F0226	142	465	15SV03F0406T	63	207	33SV8/1AG3706T	269	882	92SV3/2AG3706T	117	385
3SV14F0226	153	500	15SV04F0556T	84	275	33SV8G3706T	278	912	92SV3/1AG3706T	132	431
3SV15F0306T	164	539	15SV05F0756T	105	346	46SV1/1AG0556T	29	95	92SV3G4506T	145	475
3SV17F0306T	186	610	15SV06F1106T	127	416	46SV1G0756T	40	131	92SV4/2AG4506T	163	535
3SV19F0306T	207	680	15SV07F1106T	148	484	46SV2/2AG1106T	57	186	125SV1G1506T	40	132
3SV21F0406T	231	758	15SV08F1506T	172	564	46SV2/1AG1106T	68	222	125SV2/2AG2206T	73	240
3SV23F0406T	253	828	15SV09F1506T	193	634	46SV2G1506T	78	257	125SV3/3BG3006T	102	334
5SV02F0056	22	72	15SV10F1506T	214	703	46SV3/2AG1856T	96	313	125SV3G3706T	118	385
5SV03F0076	33	107	15SV11F1856T	236	776	46SV3/1AG1856T	106	348	125SV4/4AG4506T	146	479
5SV04F0116	44	144	15SV12F1856T	258	846	46SV3G1856T	117	385	125SV5/5AG5506T	183	599

60 Hz @1750 min⁻¹ motors

Model	m	ft	Model	m	ft	Model	m	ft	Model	m	ft
1SV03F00246T	7	22	10SV03F00546T	13	43	33SV13G07546T	112	367	1SV03F00246T	7	22
1SV05F00246T	11	36	10SV05F00546T	22	71	46SV2G01546T	19	62	1SV05F00246T	11	36
1SV07F00246T	15	50	10SV07F00746T	30	98	46SV3G02246T	29	94	1SV07F00246T	15	50
1SV09F00246T	20	64	10SV09F00746T	39	126	46SV4G03046T	38	124	1SV09F00246T	20	64
1SV11F00246T	24	78	10SV11F01146T	48	157	46SV5G04046T	48	156	1SV11F00246T	24	78
1SV13F00246T	28	93	10SV13F01146T	56	184	46SV6G05546T	58	189	1SV13F00246T	28	93
1SV15F00246T	32	106	10SV15F01546T	65	214	46SV7G05546T	67	220	1SV15F00246T	32	106
1SV17F00246T	37	120	15SV03F00546T	15	51	46SV8G07546T	77	253	1SV17F00246T	37	120
1SV18F00246T	39	127	15SV04F00746T	21	68	46SV9G07546T	86	283	1SV18F00246T	39	127

Model	m	ft	Model	m	ft	Model	m	ft	Model	m	ft
1SV20F00246T	43	141	15SV05F01146T	26	86	46SV10G07546T	96	314	1SV20F00246T	43	141
1SV22F00246T	47	154	15SV06F01146T	31	103	46SV11G11046T	106	347	1SV22F00246T	47	154
1SV24F00246T	51	168	15SV07F01546T	37	120	46SV12G11046T	115	378	1SV24F00246T	51	168
1SV26F00346T	55	181	15SV08F01546T	42	139	46SV13G11046T	125	410	1SV26F00346T	55	181
1SV28F00346T	60	197	15SV09F02246T	48	157	66SV1G01546T	11	35	1SV28F00346T	60	197
3SV02F00246T	6	18	15SV10F02246T	53	175	66SV2G03046T	21	69	3SV02F00246T	6	18
3SV04F00246T	11	36	15SV11F02246T	59	192	66SV3G04046T	31	103	3SV04F00246T	11	36
3SV06F00246T	16	53	15SV12F02246T	64	209	66SV4G05546T	42	138	3SV06F00246T	16	53
3SV08F00246T	22	71	22SV02F00546T	11	36	66SV5G07546T	53	172	3SV08F00246T	22	71
3SV10F00246T	27	88	22SV03F00746T	17	54	66SV6G07546T	63	206	3SV10F00246T	27	88
3SV12F00246T	32	105	22SV04F01146T	22	73	66SV7G11046T	73	240	3SV12F00246T	32	105
3SV14F00346T	38	123	22SV05F01546T	28	91	66SV8G11046T	84	275	3SV14F00346T	38	123
3SV15F00346T	40	133	22SV06F01546T	33	109	92SV1G01546T	12	39	3SV15F00346T	40	133
3SV17F00346T	46	149	22SV07F02246T	39	128	92SV2G03046T	23	77	3SV17F00346T	46	149
3SV19F00346T	51	166	22SV08F02246T	45	146	92SV3G05546T	35	116	3SV19F00346T	51	166
3SV21F00546T	56	183	22SV09F02246T	50	164	92SV4G07546T	47	155	3SV21F00546T	56	183
3SV23F00546T	62	203	22SV10F03046T	56	182	92SV5G07546T	59	192	3SV23F00546T	62	203
5SV03F00246T	8	27	33SV2G01146T	17	56	92SV6G11046T	70	230	5SV03F00246T	8	27
5SV05F00246T	14	45	33SV3G01546T	26	84	92SV7G11046T	82	269	5SV05F00246T	14	45
5SV07F00246T	19	62	33SV4G02246T	34	112	92SV8G15046T	94	307	5SV07F00246T	19	62
5SV09F00346T	24	79	33SV5G03046T	43	140	125SV1G02246T	10	33	5SV09F00346T	24	79
5SV11F00346T	30	97	33SV6G03046T	52	169	125SV2/2AG03046T	18	60	5SV11F00346T	30	97
5SV13F00546T	35	114	33SV7G04046T	60	197	125SV3/3BG04046T	26	84	5SV13F00546T	35	114
5SV15F00546T	40	133	33SV8G05546T	69	226	125SV4/4AG05546T	37	120	5SV15F00546T	40	133
5SV17F00546T	46	150	33SV9G05546T	78	254	125SV5/5AG07546T	46	150	5SV17F00546T	46	150
5SV19F00746T	51	167	33SV10G05546T	86	282	125SV6G11046T	59	193	5SV19F00746T	51	167
5SV21F00746T	57	186	33SV11G07546T	95	311	125SV7G11046T	69	225	5SV21F00746T	57	186
5SV23F00746T	62	203	33SV12G07546T	103	339	125SV8G15046T	78	257	5SV23F00746T	62	203

8.4 Maximum operating pressure

The diagram shows the maximum operating pressure based on unit model and temperature of pumped liquid.

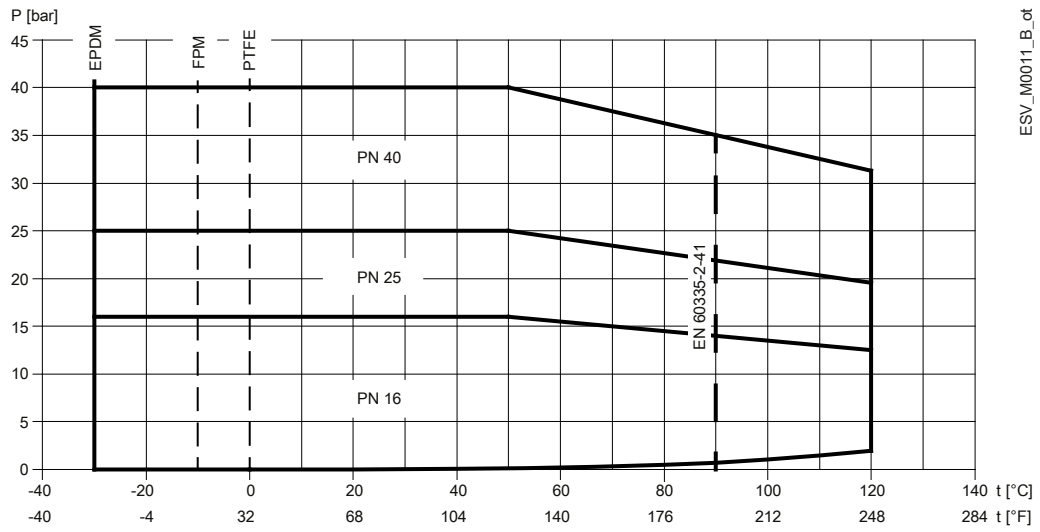

Note for the pump unit: the maximum ambient temperature is 50°C (122°F), unless otherwise stated on the data plate of the motor and/or frequency converter, if present.

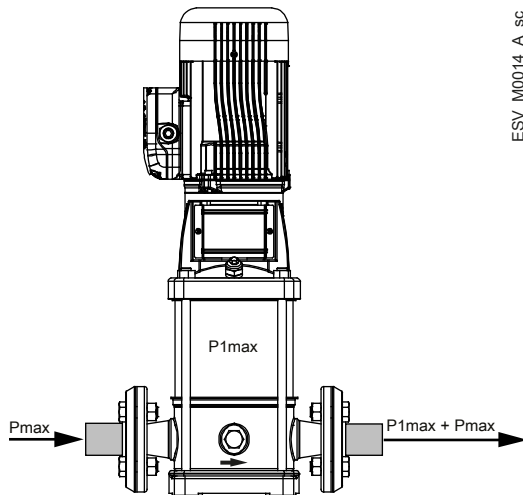

Note:
 $P1max + Pmax \leq PN$

Data	Description
P1max	Maximum input pressure
Pmax	Maximum pressure generated by the unit
PN	Maximum operating pressure

8.5 Maximum number of starts per hour

Motor power, kW (hp)	Starts / h
0.25 – 3 (0.33 – 4)	60
4 – 7.50 (5.4 – 10)	40
11 – 15 (14.8 – 20.1)	30
18.5 – 22 (24.8 – 29.5)	24
30 – 37 (40.2 – 49.6)	16
45 – 75 (60.3 – 100)	8
90 – 160 (120 – 215)	4

NOTICE:

If a motor other than the one supplied with the pump unit is used, check the maximum number of starts shown in the motor manual.

8.6 Protection class

IP 55.

8.7 Electrical specifications

See the motor data plate.

Permitted tolerances for the supply voltage

Frequency Hz	Phase ~	No. of conductors + earth	UN, V ± %
50	1	2 + 1	220÷240 ± 6
	3	3 + 1	230/400 ± 10, 400/690 ± 10
60	1	2 + 1	220÷230 ± 6
	3	3 + 1	220/380 ± 5, 380/660 ± 10

8.8 Sound pressure

Measured in free field at a distance of one metre from the unit, with standard motor operating without load.

50 Hz motors

Table 2: Sound pressure level LpA, dB ± 2

Power, kW (hp)	2 poles	4 poles
0.25 (0,33)	–	<70
0.37 (0.5) – 0.55 (0.7) – 0.75 (1) – 1 (1,3) – 1.5 (2) – 2.2 (2.9) 3 (4) – 4 (5.4) – 5.5 (7.4) – 7.5 (10)	<70	<70
11 (14.8)	73	–
15 (20) – 18.5 (25) – 22 (30)	75	–
30 (40) – 37 (50)	74	–
45 (60)	78	–
55 (74)	84*	–

* Sound pressure level LwA: 95 dB ± 2

60 Hz motors

Table 3: Sound pressure level LpA, dB ± 2

Power, kW (hp)	2 poles	4 poles
0.25 (0.33)	–	< 70
0.37 (0.5) – 0.55 (0.7) – 0.75 (1) – 1 (1.3) – 1.5 (2) – 2.2 (2.9) 3 (4) – 4 (5.4) – 5.5 (7.4)	< 70	< 70
7.5 (10) - 11 (14.8) - 15 (20)	71	< 70
18.5 (25)	73	–
22 (30)	70	–
30 (40) – 37 (50)	76	–
45 (60) - 55 (74)	79	–

8.9 Materials in contact with the liquid

Model	Materials
1, 3, 5, 10, 15, 22	Stainless steel
33, 46, 66, 92, 125	Stainless steel, cast iron

8.10 Mechanical seal

Model	Motor power, kW (hp)	Rated diameter, mm (in)	Balanced	Rotation	Version according to EN 12756
1, 3, 5	All	12 (0.47)	No	Right	K
10, 15, 22	< 5.5 (7.4)	16 (0.62)	No	Right	K
10, 15, 22	≥ 5.5 (7.4)	16 (0.62)	Yes	Right	K
33, 46, 66, 92, 125	All	22 (0.86)	Yes	Right	K

9 Disposal

9.1 Precautions



WARNING:

The unit must be disposed of through approved companies specialised in the identification of different types of materials (steel, copper, plastic, etc.).



WARNING:

It is prohibited to dispose of lubricating fluids and other hazardous substances in the environment.

9.2 WEEE 2012/19/EU (50 Hz)

(IE) (MT) (GB) Information to users (WEEE other than WEEE from private households), pursuant to art. 14 of the Directive 2012/19/EU of the European Parliament and of the Council of 4 July 2012 on waste electrical and electronic equipment (WEEE).



The crossed bin symbol on the appliance or on its packaging indicates that the product at the end of its useful life must be collected separately and not disposed of together with other mixed urban waste. The separate collection of this equipment at the end of its life is organized and managed by the producer. The user who wants to get rid of this equipment can then contact the producer and follow the system that it has adopted to allow the separate collection of equipment at the end of life, or select a supply chain independently authorized to manage. Appropriate separate collection for the subsequent start-up of the disused equipment for recycling, treatment and environmentally compatible disposal helps to avoid possible negative effects on the environment and on health and favors the re-use and / or recycling of the materials it is composed of the equipment.

(IE)

Producer of EEE as per Directive 2012/19/EU

Xylem Water Solutions Ireland Ltd - 50 Broomhill Close - Airton Road - D24 Tallaght - Dublin 24

(MT)

Producer of EEE as per Directive 2012/19/EU

-

(GB)

Producer of EEE as per Directive 2012/19/EU

Xylem Water Solutions UK Ltd - Millwey Rise Industrial Estate - Axminster - Devon EX13 5HU

10Declarations

10.1 Pump unit

EC Declaration of Conformity (Original)

Xylem Service Italia S.r.l., with headquarters in Via Vittorio Lombardi 14 - 36075 Montecchio Maggiore VI - Italy, hereby declares that the product

Pump unit (see the label on the Safety and Other Information manual)

fulfils the relevant provisions of the following European Directives:

- Machinery 2006/42/EC (ANNEX II - natural or legal person authorised to compile the technical file: Xylem Service Italia S.r.l.)
- Eco-design 2009/125/EC, Regulation (EC) No 640/2009 & Regulation (EU) No 4/2014 (Motor 3 ~, 50 Hz, PN \geq 0.75 kW) if IE2 or IE3 marked, Regulation (EU) No 547/2012 (water pump) if MEI marked

and the following technical standards:

- EN ISO 12100:2010, EN 809:1998+A1:2009, EN 60335-1:2012+ A11:2014+A13:2017, EN 60335-2- 41:2003+A1:2004+A2:2010, EN 62233:2008, EN 60204-1:2006+ A1:2009^(*)
- EN 60034-30:2009, EN 60034-2-1:2007

^(*) Un 1~ > 250 V, 3~ > 480 V

Montecchio Maggiore, 30/04/2019

Amedeo Valente
(Director of Engineering and R&D)



rev.00

EU Declaration of Conformity (n. 06)

1. (EMCD) Apparatus/Product model:
see the label on the Safety and Other Information manual
(RoHS) Unique EEA identification:
N. SV.
2. Name and address of the manufacturer:
Xylem Service Italia S.r.l.
Via Vittorio Lombardi 14
36075 Montecchio Maggiore VI
Italy.
3. This declaration of conformity is issued under the sole responsibility of the manufacturer.
4. Object of the declaration:
Pump unit
5. The object of the declaration described above is in conformity with the relevant Union harmonization legislation:
 - 2014/30/EU Directive of 26 February 2014 (electromagnetic compatibility)
 - 2011/65/EU Directive of 8 June 2011 (restriction of the use of certain hazardous substances in electrical and electronic equipment).
6. References to the relevant harmonized standards used or references to the other technical specifications, in relation to which conformity is declared:
 - EN 61000-6-1:2007, EN 61000-6-3:2007+A1:2011
 - EN 50581:2012.
7. Notified body: -.
8. Additional information:
(RoHS) Annex III - exemptions - 6a, 6b, 6c.

Signed for and on behalf of: Xylem Service Italia S.r.l.

Montecchio Maggiore, 30/04/2019

Amedeo Valente
(Director of Engineering and R&D)



rev.00

Lowara is a trademark of Xylem Inc. or one of its subsidiaries.

10.2 Pump

EC Declaration of Conformity (Original)

Xylem Service Italia S.r.l., with headquarters at Via Vittorio Lombardi 14 - 36075 Montecchio Maggiore VI - Italy, hereby declares that the product:

pump (see the label on the Safety and Other Information manual)

fulfils the relevant provisions of the following European Directives:

- Machinery 2006/42/EC (ANNEX II - natural or legal person authorised to compile the technical file: Xylem Service Italia S.r.l.)
- Eco-design 2009/125/EC, Regulation (EU) no. 547/2012 (water pump) if MEI marked

and the following technical standards:

EN ISO 12100:2010, EN 809:1998+A1:2009

Montecchio Maggiore, 30/04/2019

Amedeo Valente
(Director of Engineering and R&D)



rev.00

Lowara is a trademark of Xylem Inc. or one of its subsidiaries.

11 Warranty

11.1 Information

For information on the warranty refer to the documentation of the sale contract.

Xylem |'zīləm|

- 1) The tissue in plants that brings water upward from the roots;
- 2) A leading global water technology company.

We're a global team unified in a common purpose: creating innovative solutions to meet our world's water needs. Developing new technologies that will improve the way water is used, conserved, and re-used in the future is central to our work. We move, treat, analyze, and return water to the environment, and we help people use water efficiently, in their homes, buildings, factories and farms. In more than 150 countries, we have strong, long-standing relationships with customers who know us for our powerful combination of leading product brands and applications expertise, backed by a legacy of innovation.

For more information on how Xylem can help you, go to www.xylem.com



Xylem Service Italia S.r.l.
Via Vittorio Lombardi 14
36075 - Montecchio Maggiore (VI) - Italy
xylem.com/lowara

Lowara is a trademark of Xylem Inc. or one of its subsidiaries.
© 2019 Xylem, Inc. Cod.001080194EN rev.C ed.07/2022